

BYSTRONIC STYLE

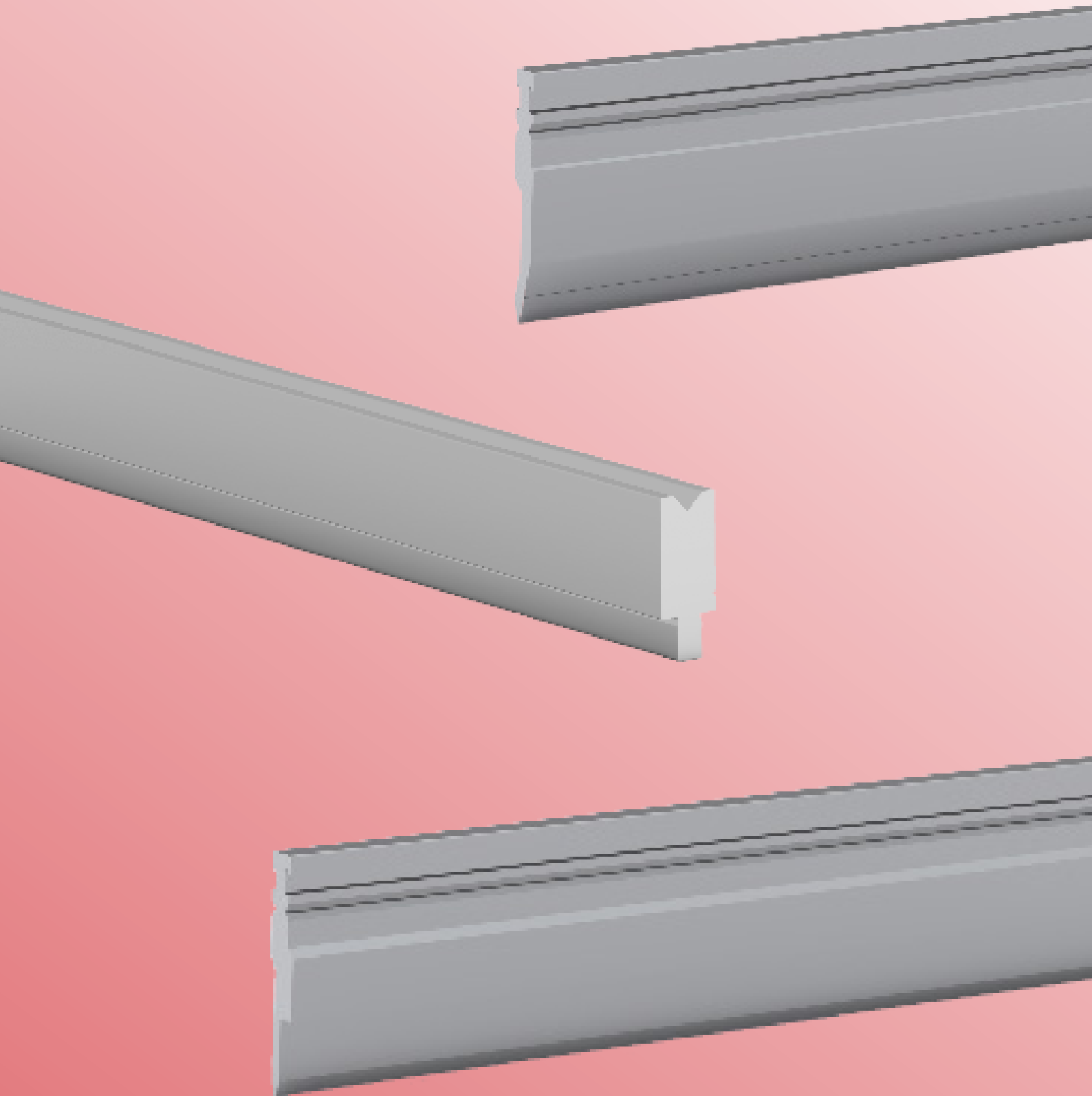

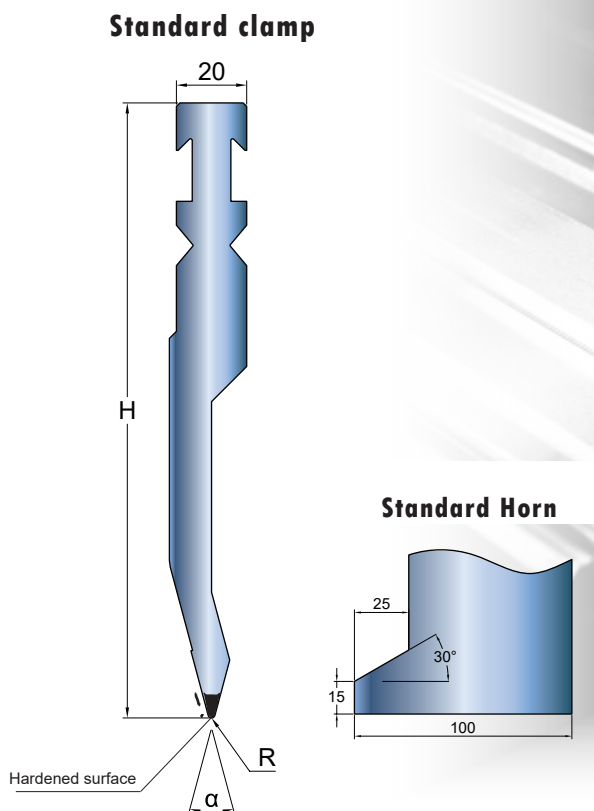

Standardowe długości - Standard lengths

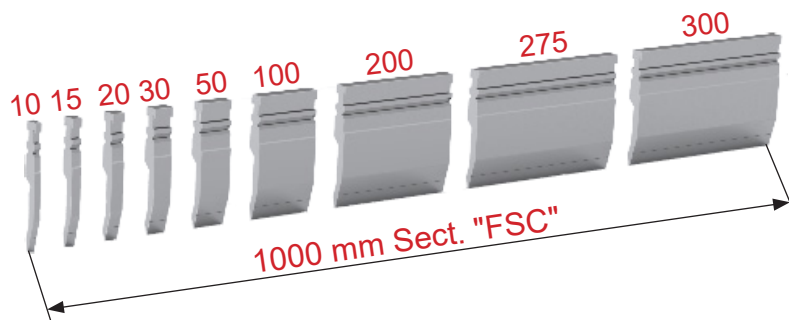
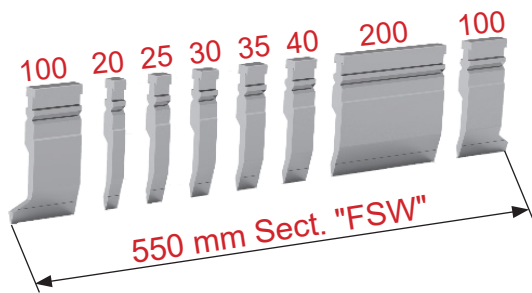
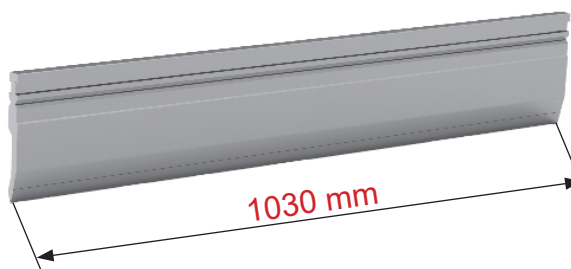
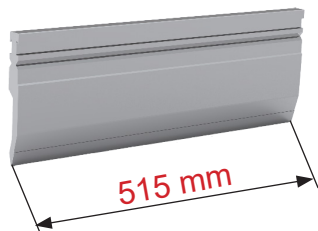

UWAGA / NOTE

Przekrój 1100mm FSL dostępny na zamówienie:

1100mm FSL sectioning available on request:

10 - 15 - 20 - 30 - 50 - 100 - 200 - 300 - 375

Dostępne długości na zamówienie

10 - 15 - 20 - 25 - 30 - 35 - 40 - 45 - 50 - 55 - 60 - 65 - 70 - 75 - 80 - 90 - 95 - 100 - 200 - 275 - 300

On request are available these lengths

10 - 15 - 20 - 25 - 30 - 35 - 40 - 45 - 50 - 55 - 60 - 65 - 70 - 75 - 80 - 90 - 95 - 100 - 200 - 275 - 300

** : / Horns available individually

The horns' max load is 50% of the max load of the punch.



BE P2RFA

kN/m	α	Mt	R	H
1000	85°	■	1.0	175

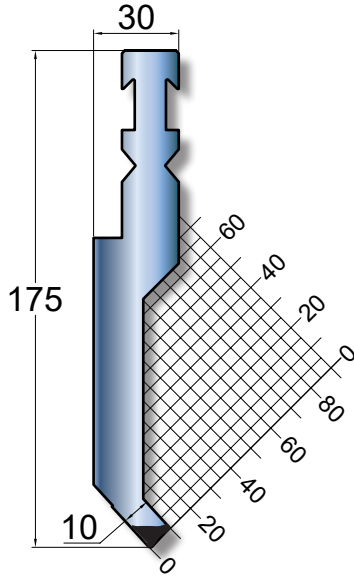

BE P2RFA250

kN/m	α	Mt	R	H
1000	85°	■	1.0	250

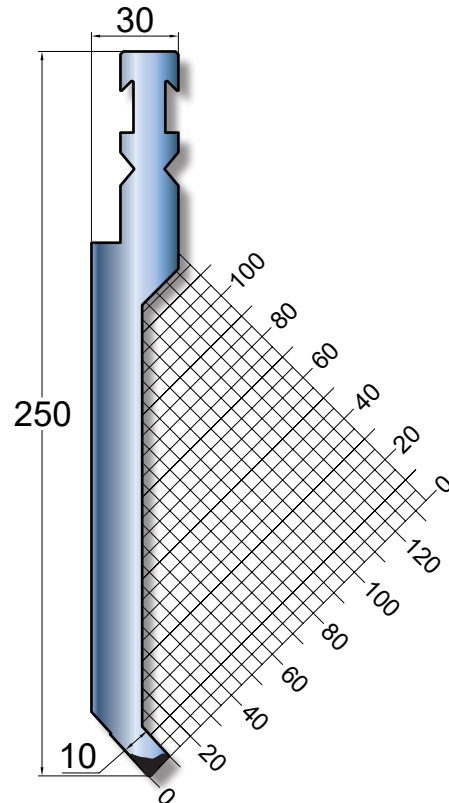

BE P3RFA

kN/m	α	Mt	R	H
1300	85°	■	1.0	175

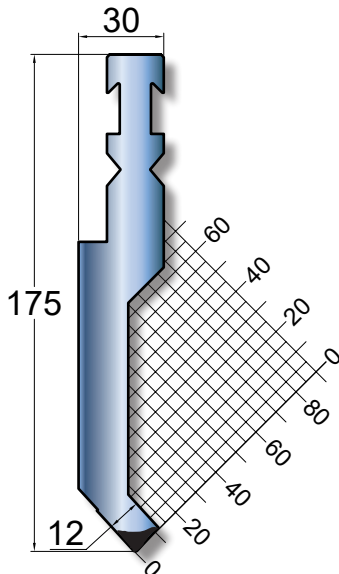

BE P3RFA250

kN/m	α	Mt	R	H
1300	85°	■	1.0	250

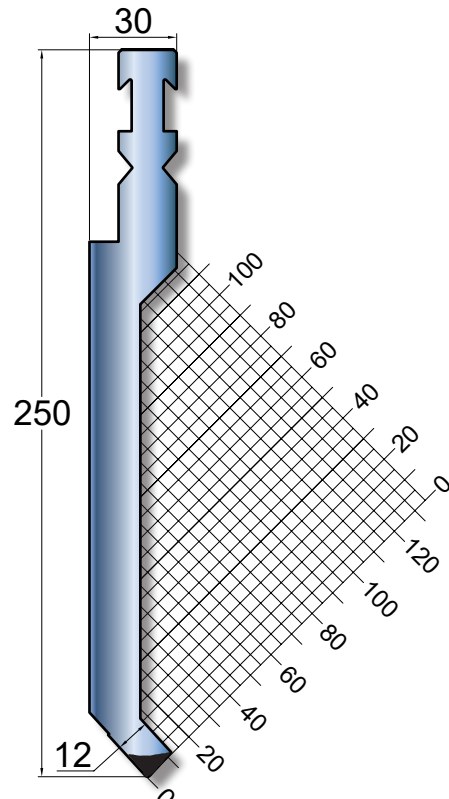



BE P4RFA

kN/m	α	Mt	R	H
600	85°	■	1.0	175
			1.5	175

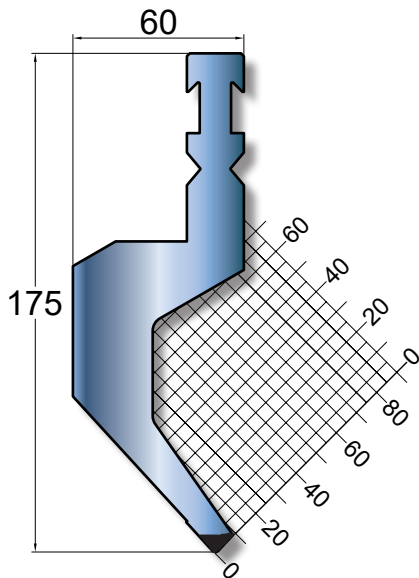

BE P4RFA250

kN/m	α	Mt	R	H
600	85°	■	1.0	250
			1.5	250

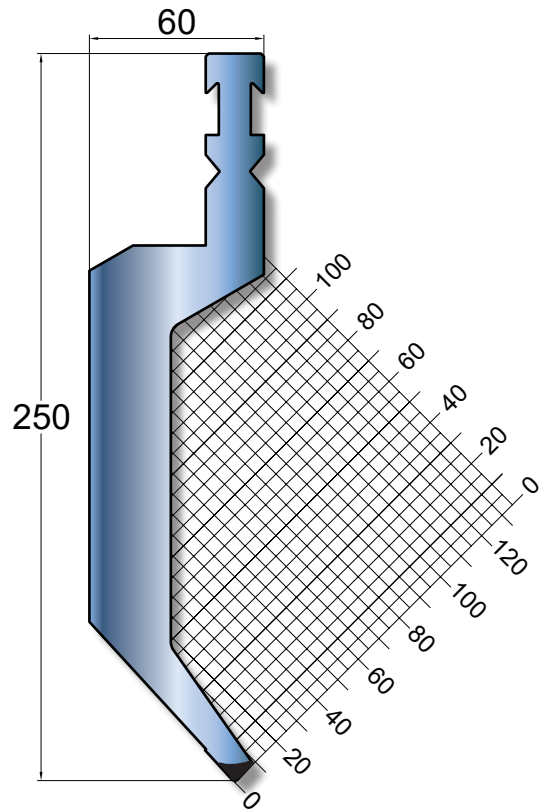

BE P8RFA

kN/m	α	Mt	R	H
1000	85°	■	1.0	175

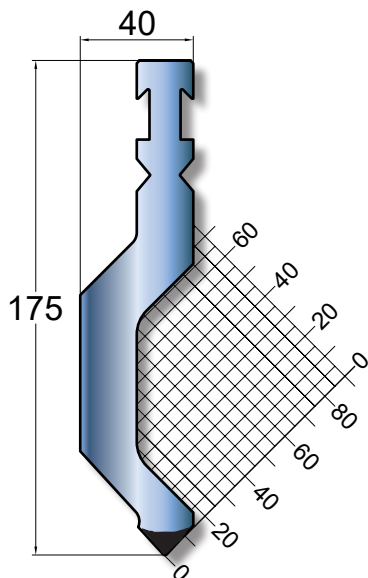

BE P8RFA250

kN/m	α	Mt	R	H
1000	85°	■	1.0	250

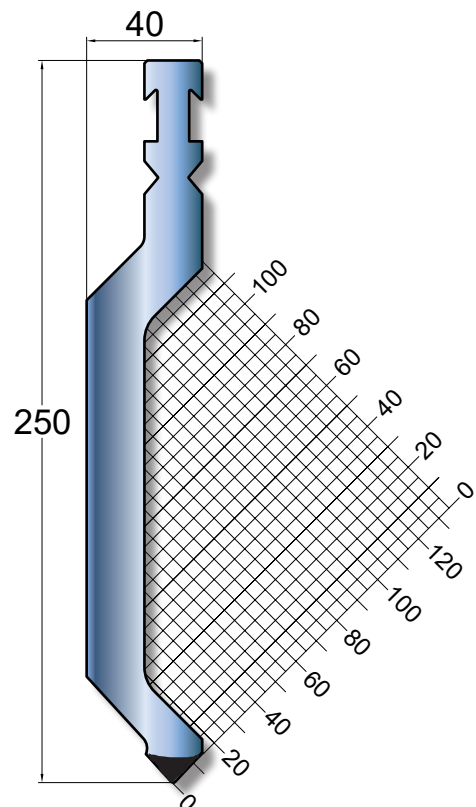



BE P5RFA

kN/m	α	Mt	R	H
1000	30°	■	1.0	175

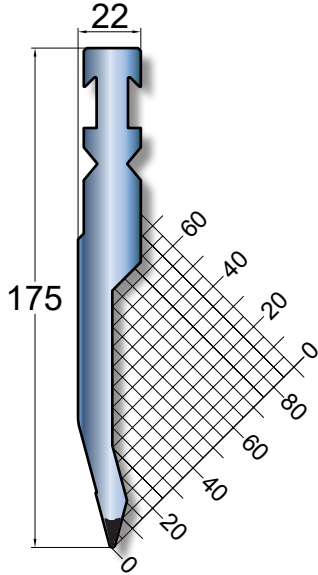

BE P5RFA250

kN/m	α	Mt	R	H
750	30°	■	1.0	250

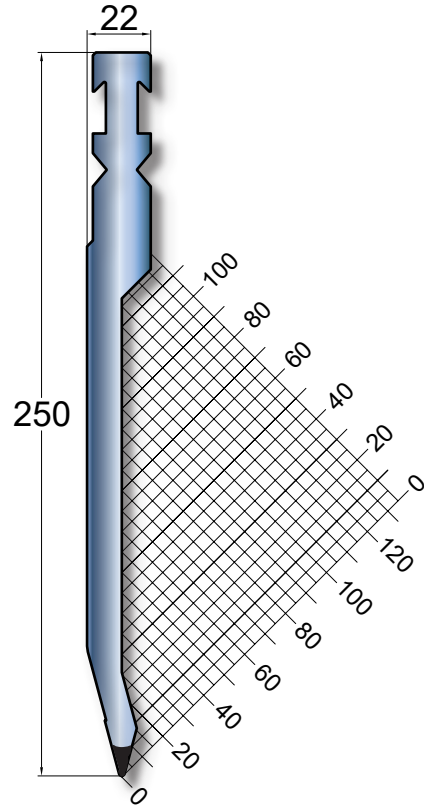

BE P6RFA

kN/m	α	Mt	R	H
1500	30°	■	1.0	175

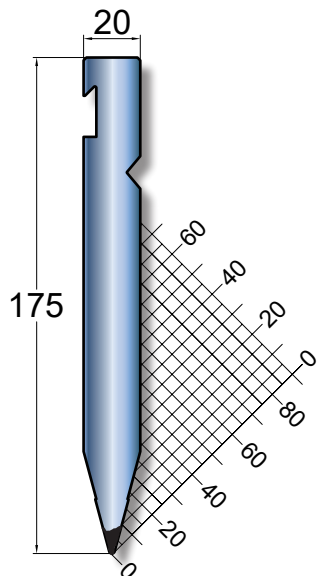

BE P6RFA250

kN/m	α	Mt	R	H
1500	30°	■	1.0	250

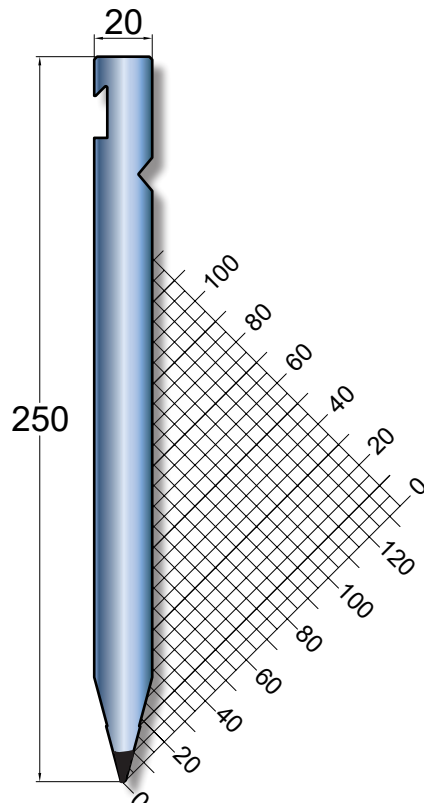



BE P7RFA

kN/m	α	Mt	R	H
1600	30°	■	3.0	175

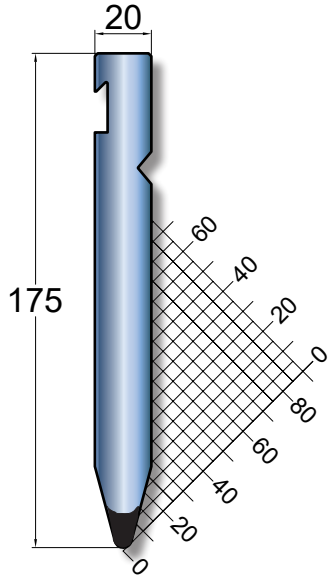

BE P7RFA250

kN/m	α	Mt	R	H
1600	30°	■	3.0	250

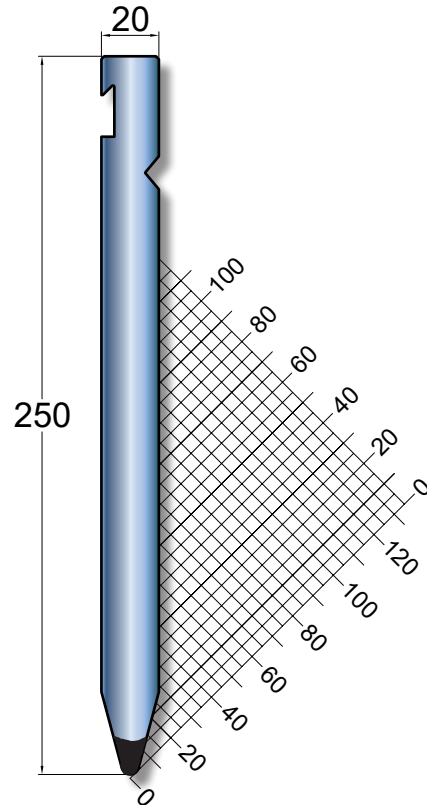

BE P9RFA

kN/m	α	Mt	R	H
1600	60°	■	4.0	175

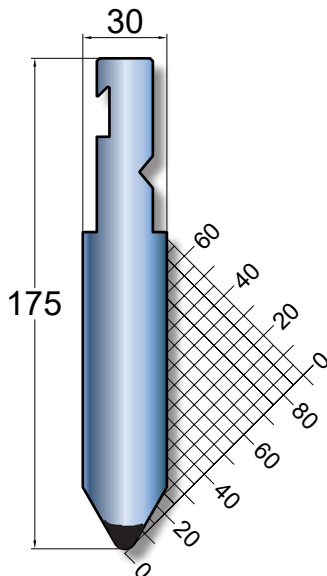

BE P9RFA250

kN/m	α	Mt	R	H
1600	60°	■	4.0	250

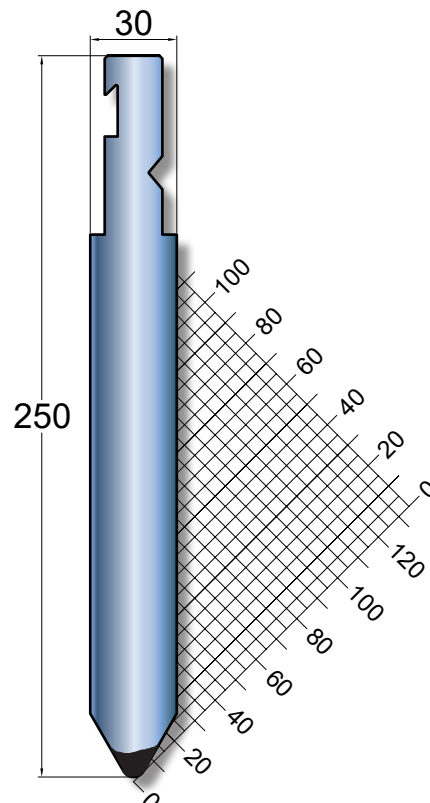

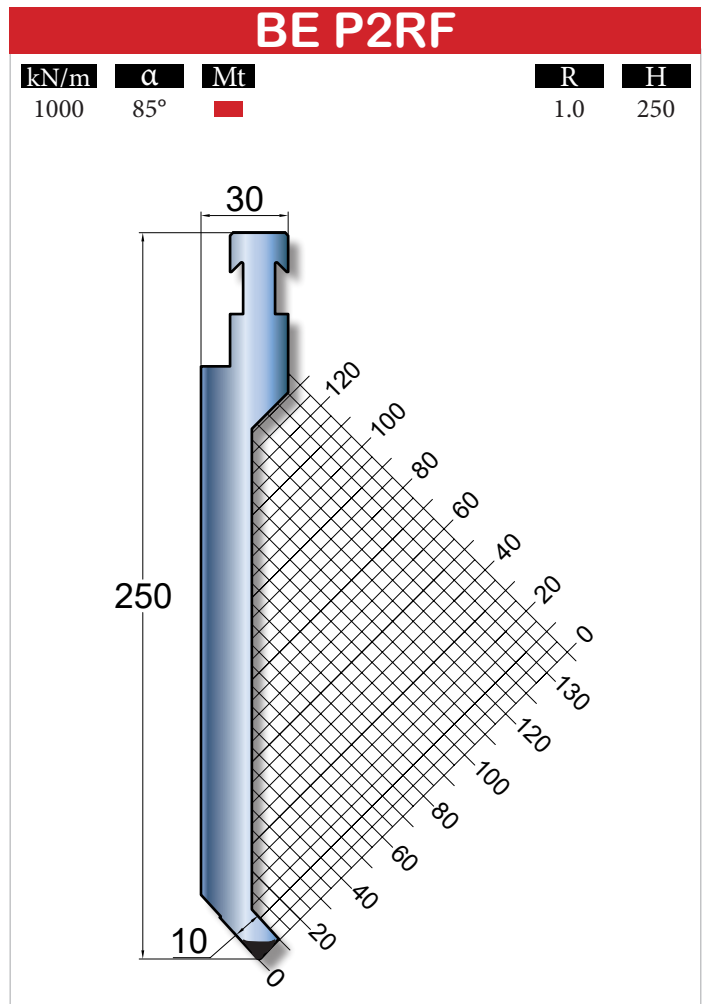
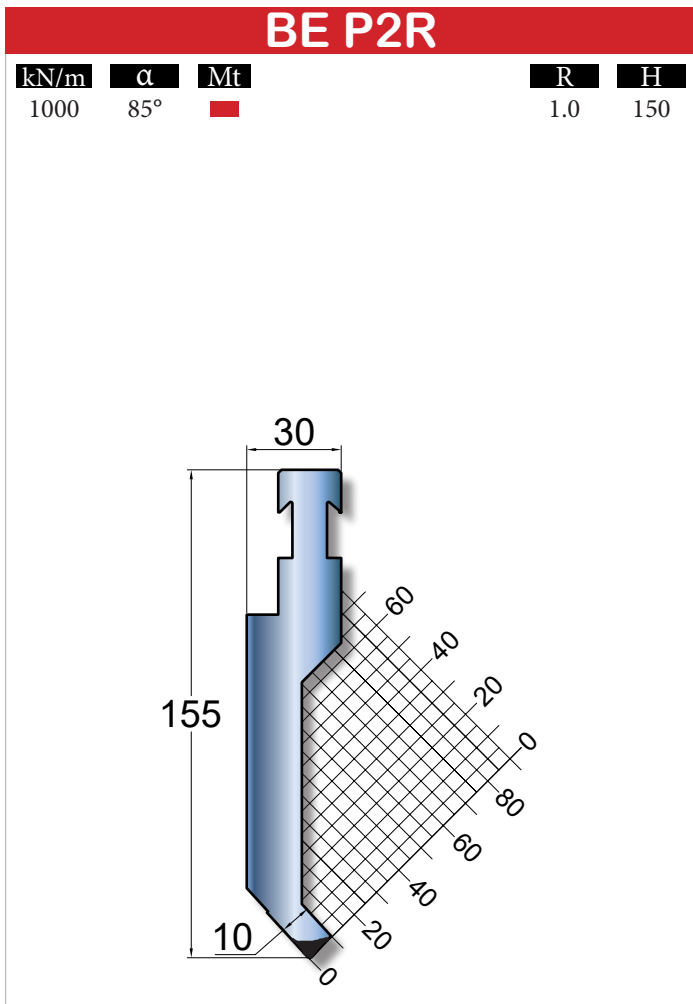
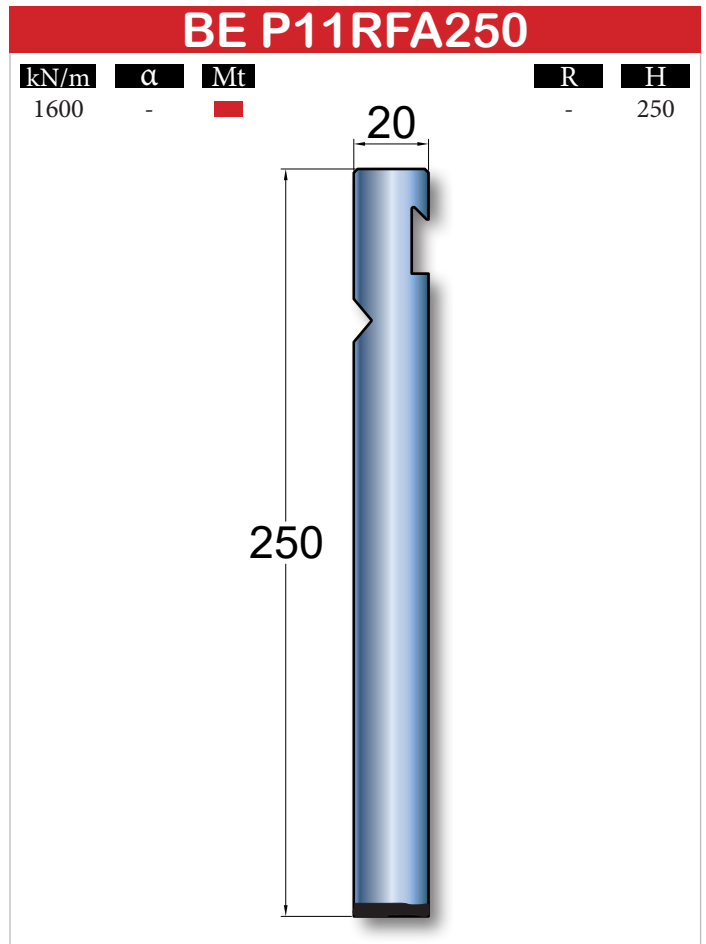
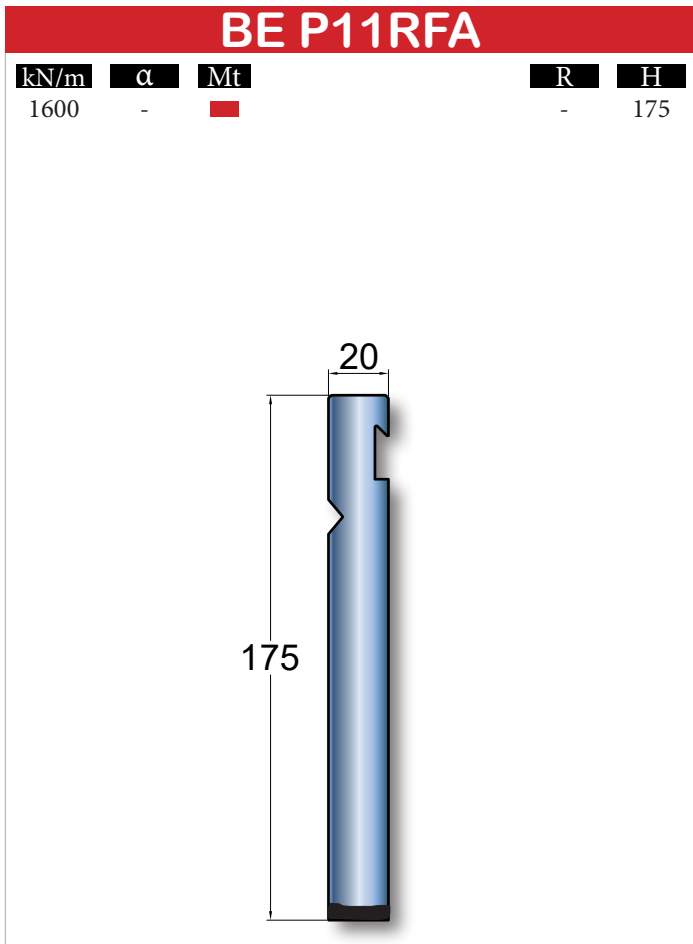



BE P3R

kN/m	α	Mt	R	H
1300	85°	■	1.0	155

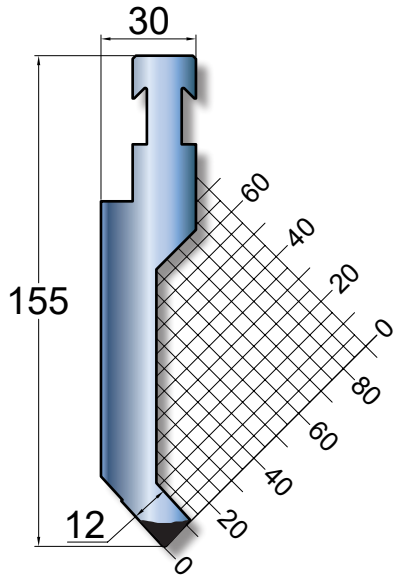

BE P4R

kN/m	α	Mt	R	H
600	85°	■	1.0	155
			1.5	155

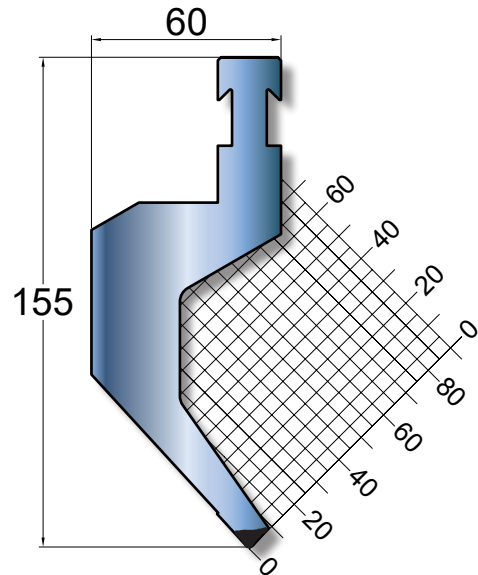

BE P4RF

kN/m	α	Mt	R	H
700	85°	■	1.0	250
			1.5	250

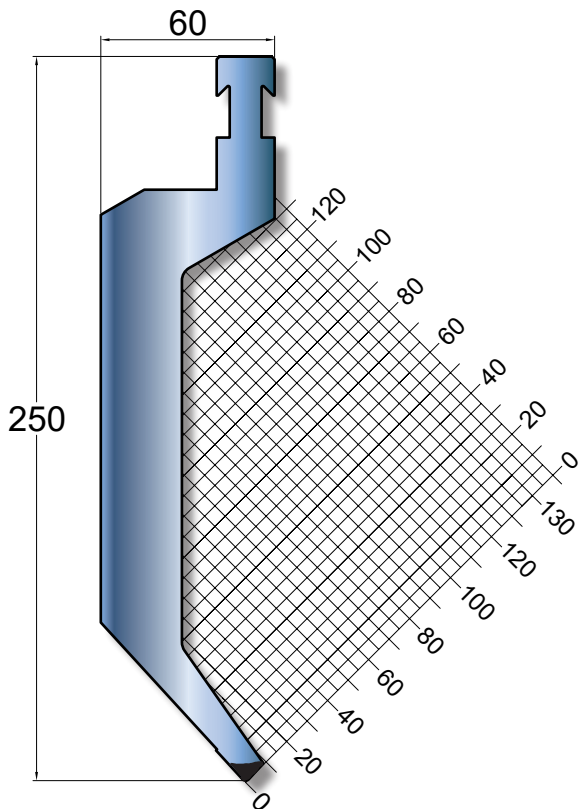

BE P8R

kN/m	α	Mt	R	H
1000	85°	■	1.0	155

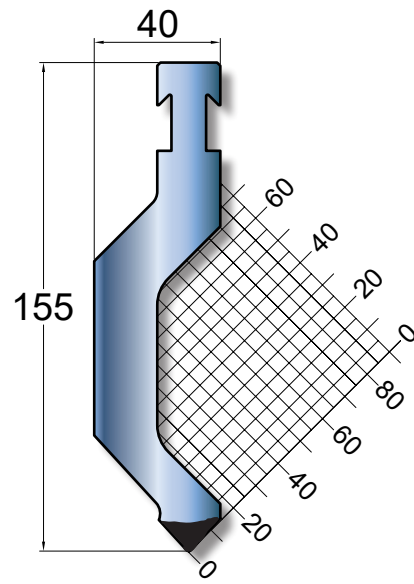



BE P5R

kN/m	α	Mt	R	H
1000	30°	■	1.0	155

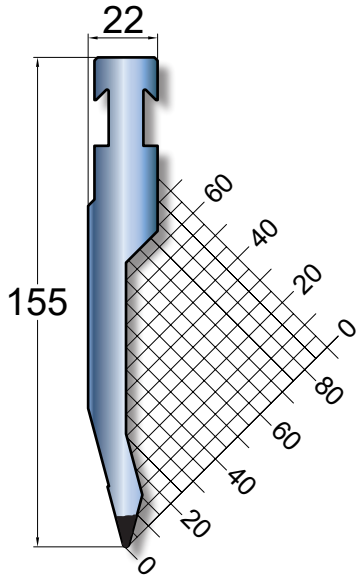

BE P5RFA

kN/m	α	Mt	R	H
750	30°	■	1.0	250

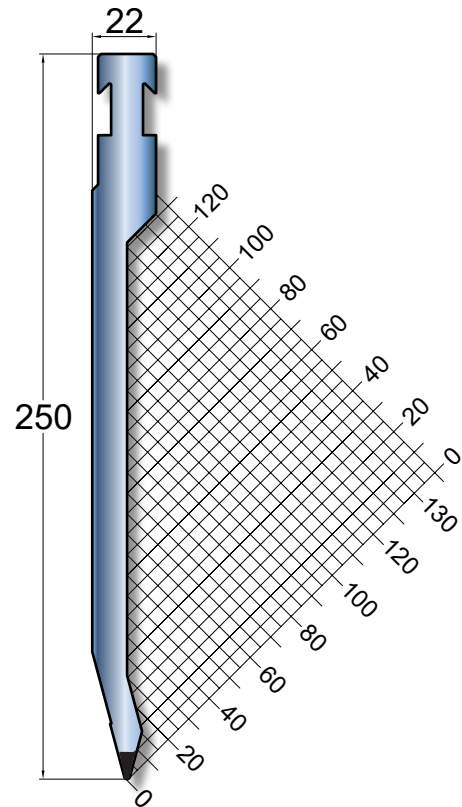

BE P6R

kN/m	α	Mt	R	H
1500	30°	■	1.0	155

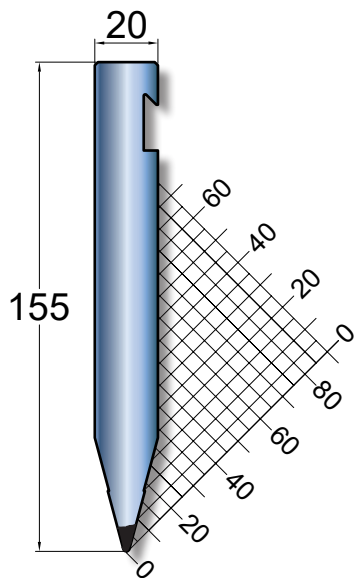



BE P7R

kN/m	α	Mt	R	H
1600	30°	■	3.0	155

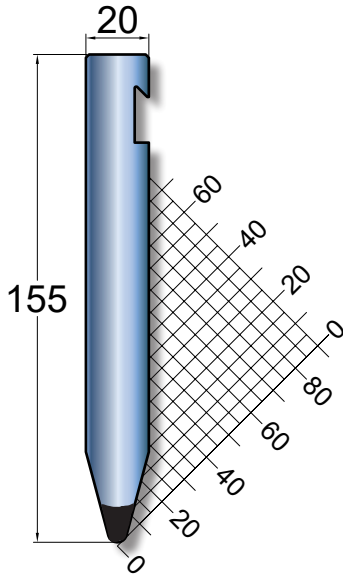

BE P7RFA

kN/m	α	Mt	R	H
1600	30°	■	3.0	250

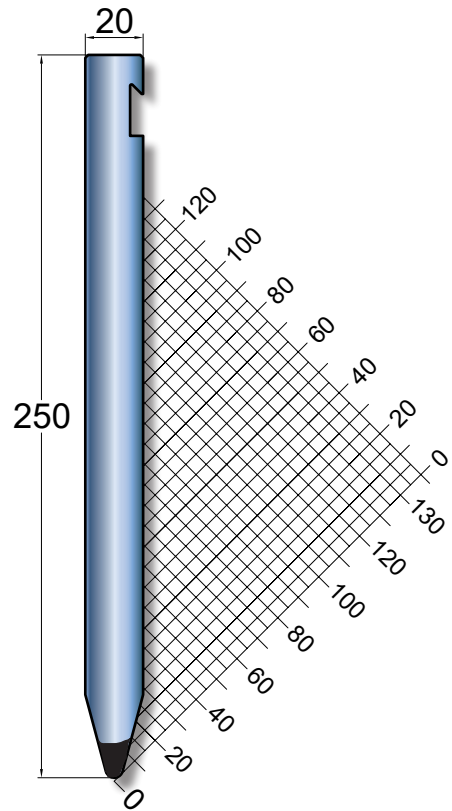

BE P9R

kN/m	α	Mt	R	H
1600	60°	■	4.0	155

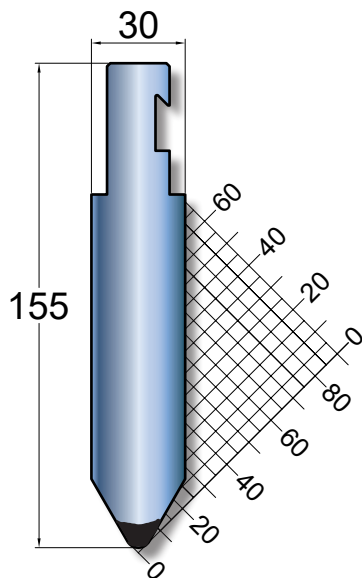

BE P11R

kN/m	α	Mt	R	H
1600	-	■	-	155

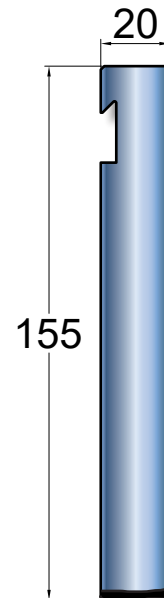

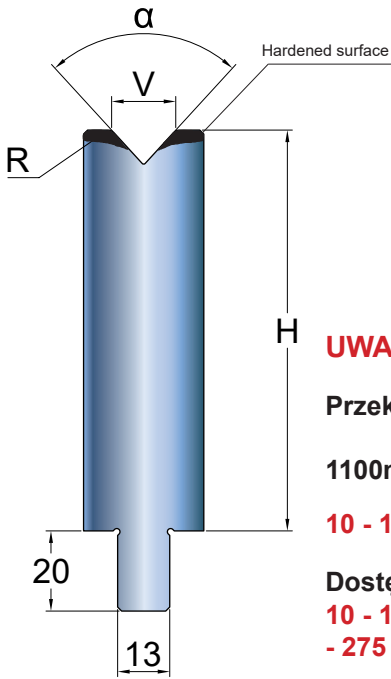

UWAGA / NOTE

Przekrój 1100mm FSL dostępny na zamówienie:

1100mm FSL sectioning available on request:

10 - 15 - 20 - 30 - 50 - 100 - 200 - 300 - 375

Dostępne długości na zamówienie

10 - 15 - 20 - 25 - 30 - 35 - 40 - 45 - 50 - 55 - 60 - 65 - 70 - 75 - 80 - 90 - 95 - 100 - 200 - 275 - 300

On request are available these lengths

10 - 15 - 20 - 25 - 30 - 35 - 40 - 45 - 50 - 55 - 60 - 65 - 70 - 75 - 80 - 90 - 95 - 100 - 200 - 275 - 300

Standard clamp

Standardowe długości - Standard lengths

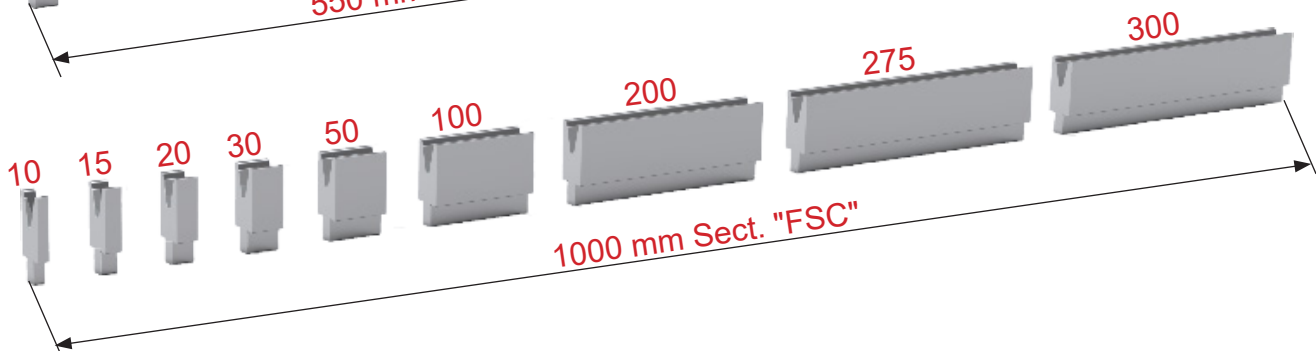
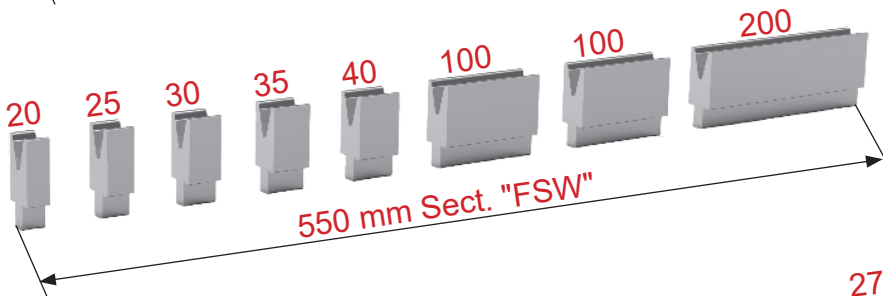
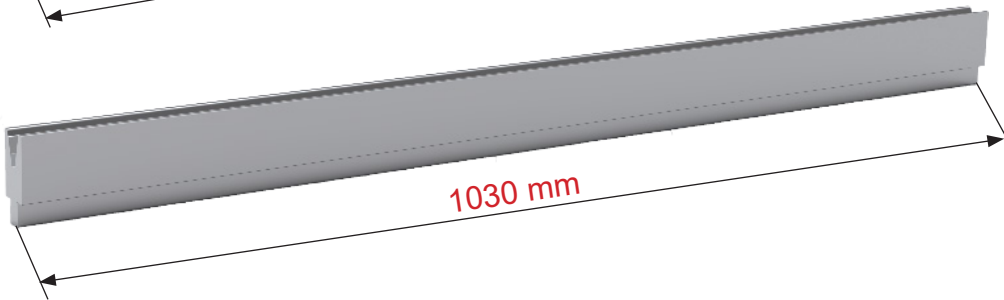
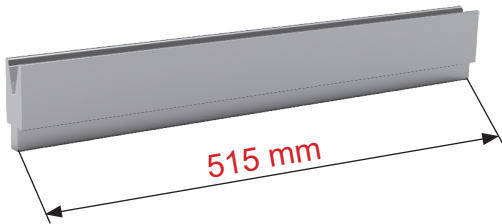

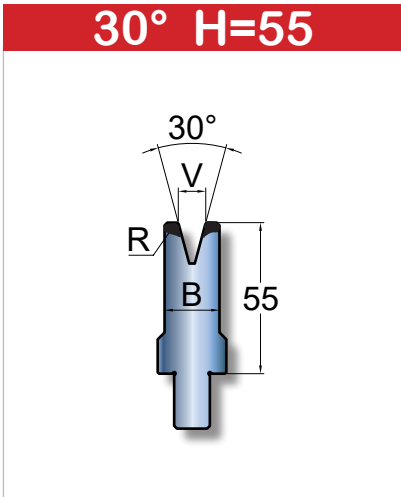

KOD	V	R	B	kN/m	Mt
BE M6	6	0.75	20	800	■
BE M8	8	1.00	20	1000	■
BE M10	10	1.00	20	700	■

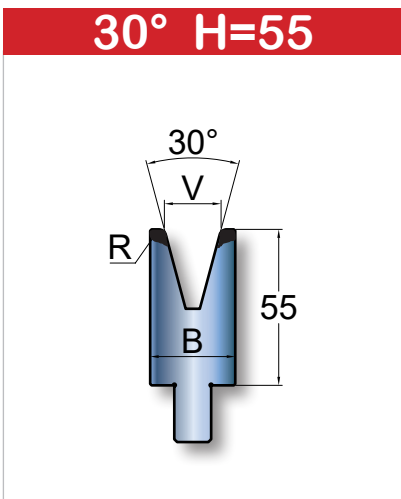

KOD	V	R	B	kN/m	Mt
BE M12	12	1.50	25	850	■
BE M16	16	2.00	30	1000	■
BE M20	20	2.50	30	600	■
BE M24	24	3.00	40	1100	■
BE M32	32	4.00	48	1100	■

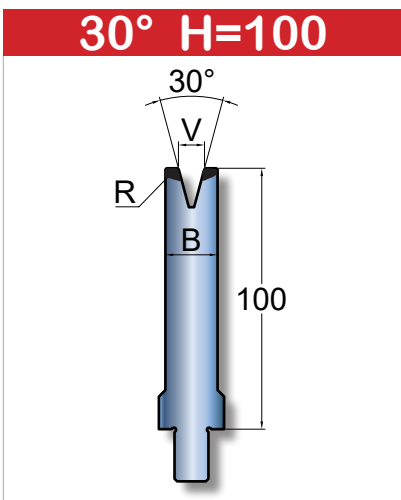

KOD	V	R	B	kN/m	Mt
BE M630H100	6	0.75	20	800	■
BE M830H100	8	1.00	20	1000	■
BE M1030H100	10	1.00	20	700	■

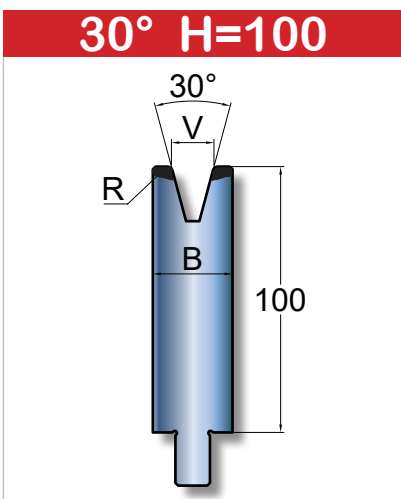

KOD	V	R	B	kN/m	Mt
BE M1230H100	12	1.50	25	900	■
BE M1630H100	16	2.00	30	1000	■
BE M2030H100	20	2.50	30	600	■
BE M2430H100	24	3.00	40	1100	■
BE M3230H100	32	4.00	48	1100	■

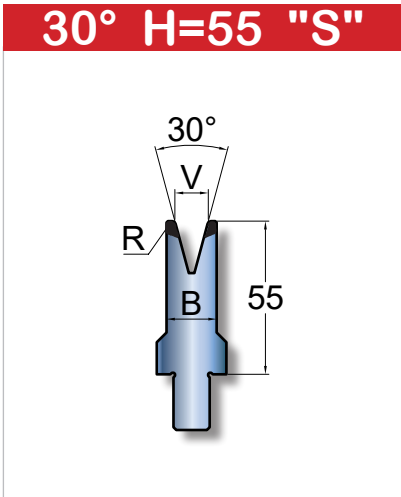

KOD	V	R	B	kN/m	Mt
BE M6S	6	0.75	12	400	■
BE M8S	8	1.00	14	400	■
BE M10S	10	1.00	16	350	■
BE M12S	12	1.50	18	350	■

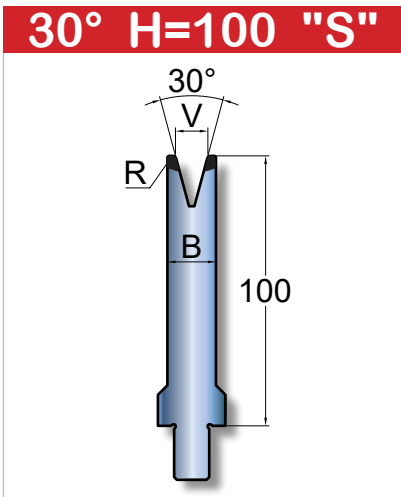

KOD	V	R	B	kN/m	Mt
BE M6S30H100	6	0.75	12	400	■
BE M8S30H100	8	1.00	14	400	■
BE M10S30H100	10	1.00	16	400	■
BE M12S30H100	12	1.50	18	350	■

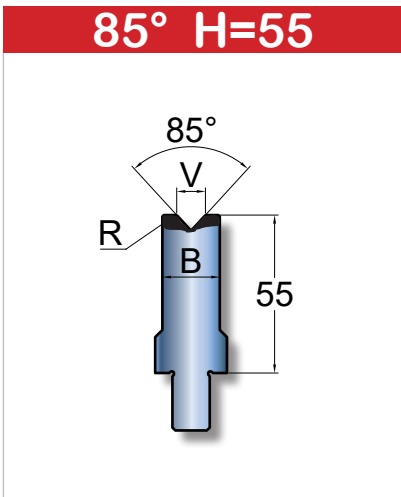

KOD	V	R	B	kN/m	Mt
BE M685	6	0.75	20	800	■
BE M885	8	0.75	20	850	■
BE M1085	10	1.00	20	800	■

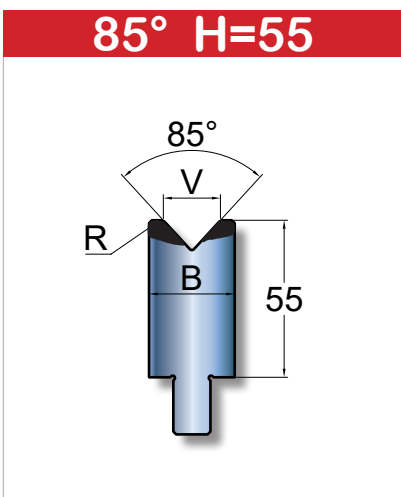

KOD	V	R	B	kN/m	Mt
BE M1285	12	1.50	25	900	■
BE M1685	16	2.00	30	1200	■
BE M2085	20	2.50	30	1400	■
BE M2485	24	3.00	40	1700	■

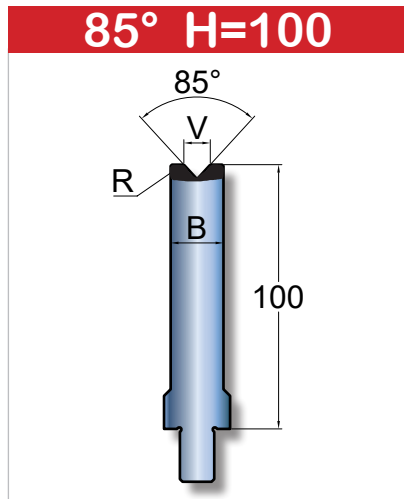

KOD	V	R	B	kN/m	Mt
BE M685H100	6	0.75	20	800	■
BE M885H100	8	0.75	20	850	■
BE M1085H100	10	1.00	20	800	■

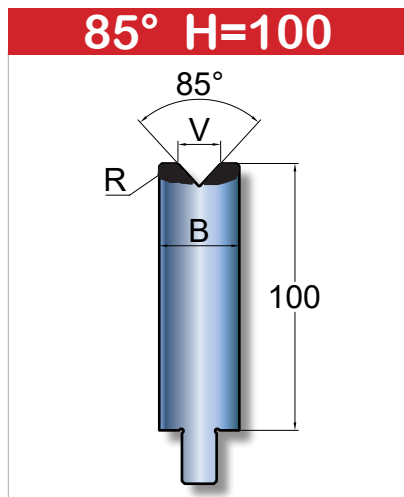

KOD	V	R	B	kN/m	Mt
BE M1285H100	12	1.50	25	900	■
BE M1685H100	16	2.00	30	1200	■
BE M2085H100	20	2.50	30	1400	■
BE M2485H100	24	3.00	40	1700	■
BE M3285H100	32	4.00	48	2400	■
BE M4085H100	40	5.00	55	2400	■
BE M5085H100	50	6.00	70	3000	■
BE M6085H100	60	7.00	80	2400	■

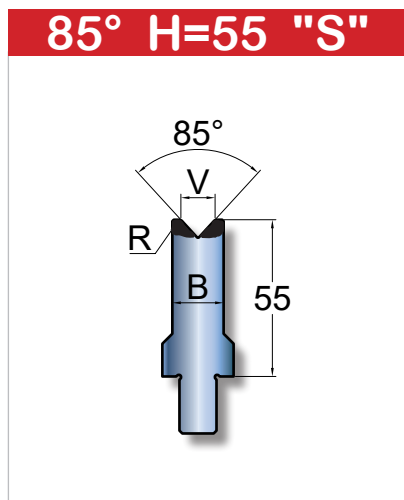

KOD	V	R	B	kN/m	Mt
BE M6S85	6	0.75	12	800	■
BE M8S85	8	0.75	14	800	■
BE M10S85	10	1.00	16	700	■
BE M12S85	12	1.50	18	900	■

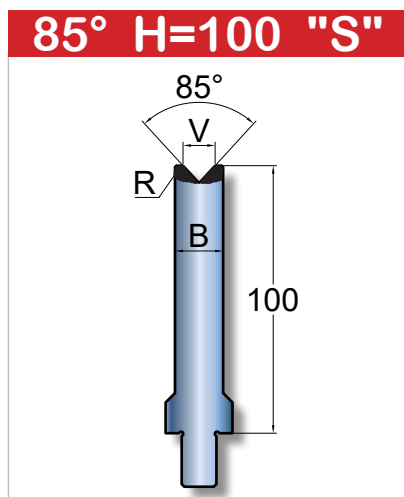

KOD	V	R	B	kN/m	Mt
BE M6S85H100	6	0.75	12	800	■
BE M8S85H100	8	0.75	14	800	■
BE M10S85H100	10	1.00	16	700	■
BE M12S85H100	12	1.50	18	900	■
BE M16S85H100	16	2.00	24	1000	■
BE M20S85H100	20	2.50	26	1100	■

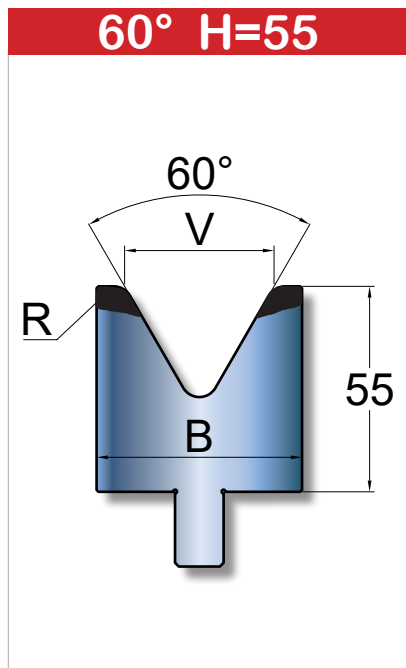

KOD	V	R	B	kN/m	Mt
BE M4060	40	5.00	55	1800	■
BE M5060	50	5.00	70	1800	■
BE M6060	60	7.00	80	1600	■

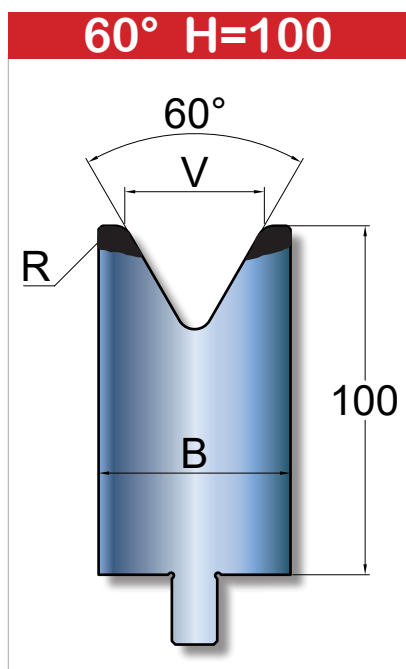

KOD	V	R	B	kN/m	Mt
BE M4060H100	40	5.00	55	2000	■
BE M5060H100	50	5.00	70	2000	■
BE M6060H100	60	7.00	80	1600	■

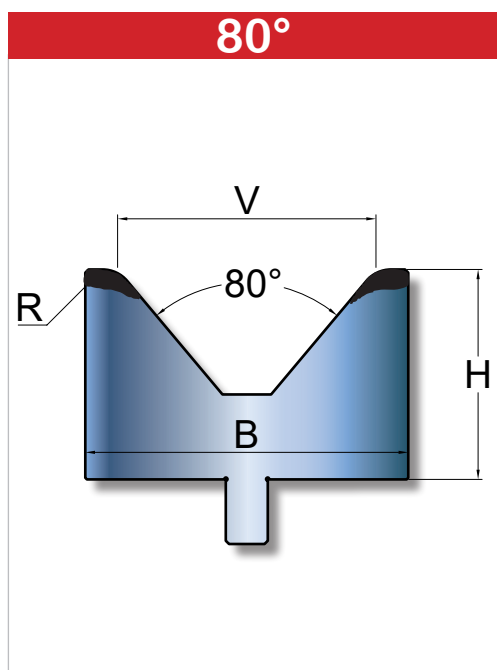

KOD	V	R	H	B	kN/m	Mt
BE M8080H65	80	10.00	65	100	1600	■
BE M10080H85	100	12.00	85	125	2000	■
BE M12080H105	120	15.00	105	160	2400	■



kN/m	α	R	Mt	KOD	B
1000	30°	1.0	■	BE P90006RFA	6
				BE P90008RFA	8
				BE P90010RFA	10
				BE P90012RFA	12

Dostępne również z zaciskami "R"

Available also with "R" clamp

kN/m	Mt	KOD	R	V
250	■	BE M90006	0.8	6
		BE M90008	0.8	8
		BE M90010	1.0	10
		BE M90012	1.2	12

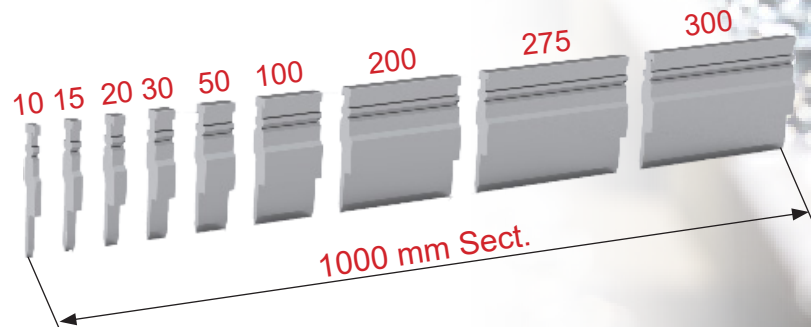
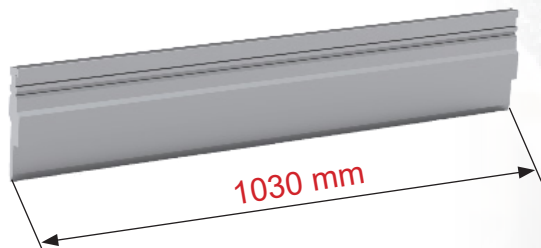
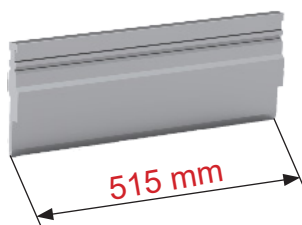
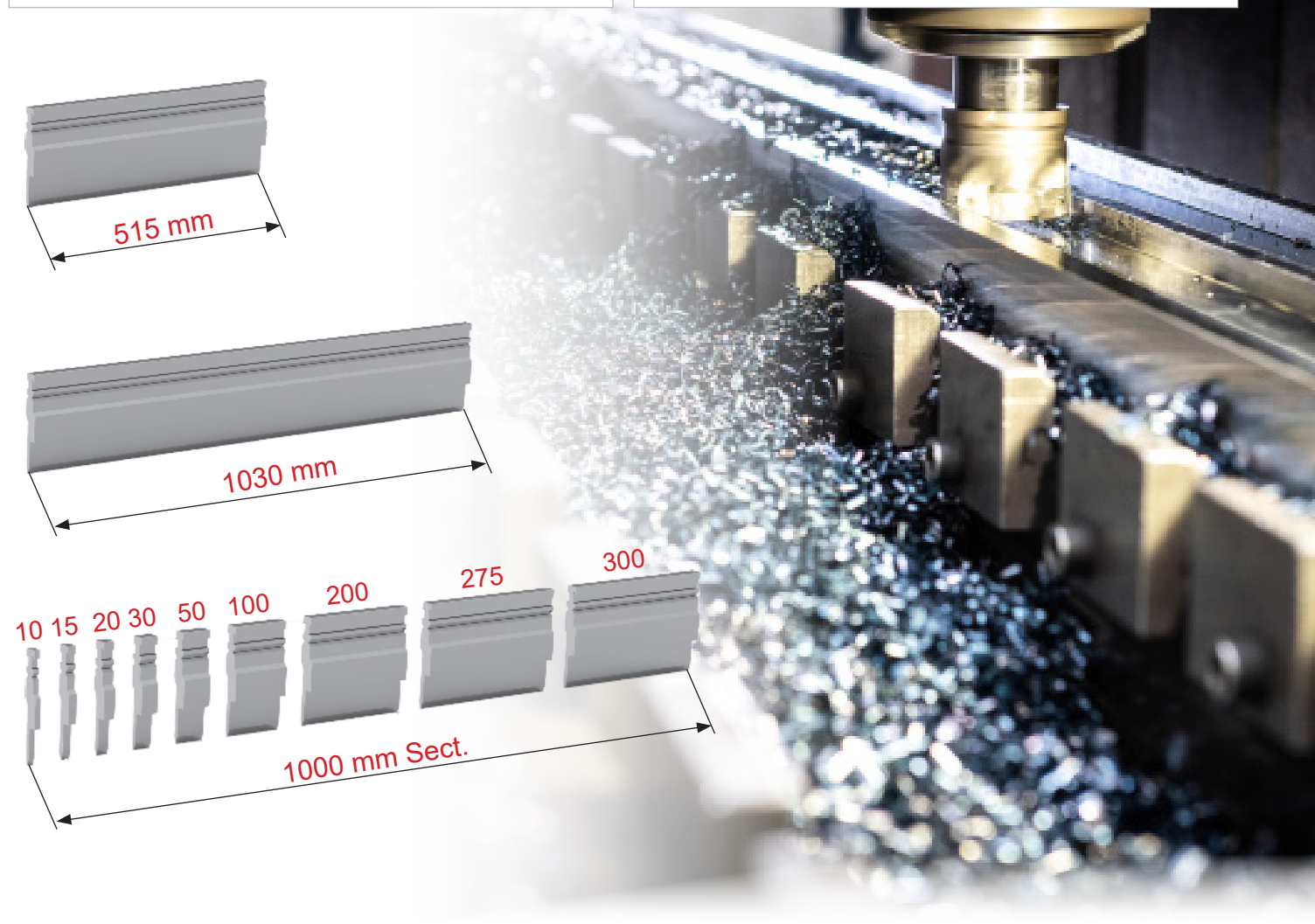



Standardowe długości - Standard Lengths

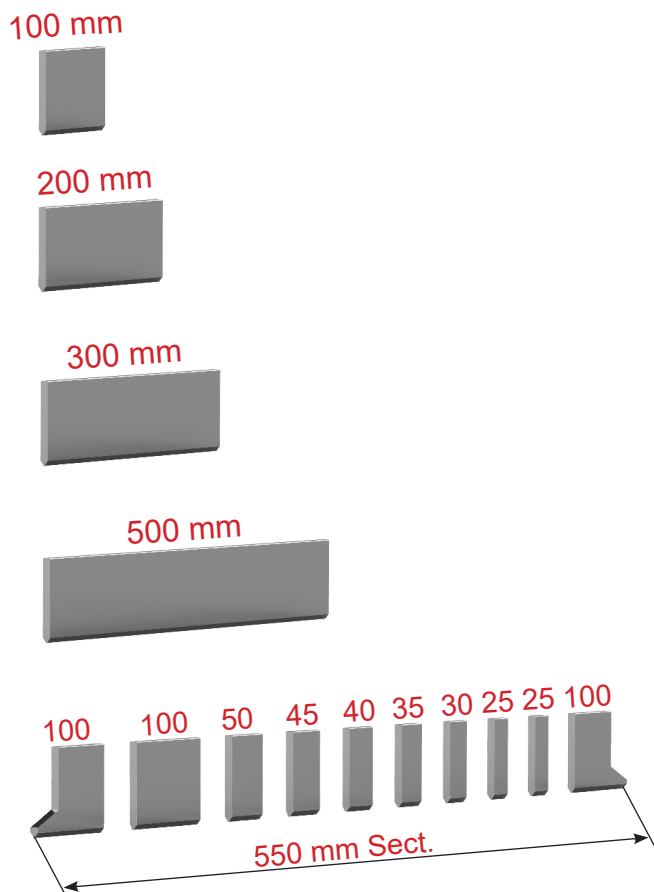

BE PTS70

kN/m	Mt		H
1000	■		70

BE PTS95

kN/m	Mt		H
1000	■		95

Blades for BE PTS70 - BE PTS95

kN/m	KOD	α	R	H	Mt
1000	TR 776	86°	1.0	100	■
	TR 774	84°	1.0	100	■
	TR 769	28°	6.0	100	■
	TR 768	28°	5.0	100	■
	TR 767	28°	4.0	100	■
	TR 766	28°	3.0	100	■
	TR 765	28°	2.0	100	■
	TR 763	28°	1.0	100	■
	TR 761	28°	0.5	100	■

Dostępne długości
Lengths available

100 mm
200 mm
300 mm
500 mm
550 mm Sect.

Rogi w zestawie
Horns included



BE P10R

kN/m 1600	Mt ■	H 130
---------------------	---	-----------------

Dostępne długości
Lengths available

515 mm
1030 mm

BE P12R

kN/m 1600	Mt ■	H 110
---------------------	---	-----------------

Dostępne długości
Lengths available

515 mm
550 mm Sect.
1000 mm Sect.

Rounds for BE P10R

kN/m 1600	Mt ■ ■	KOD	Φ
---------------------	---	------------	----------

Dostępne długości
Lengths available

515 mm
1030 mm

UWAGA / NOTE

Il codice per ordinare il modello 42CrMo4 contiene una "H" (es: BE PBD28H).

The code for the version 42CrMo4 contains an "H" (ex: BE PBD28H).

Rounds for BE P12R

kN/m 4000	Mt ■ ■	KOD	R
---------------------	---	------------	----------

Dostępne długości
Lengths available

515 mm
550 mm Sect.
1000 mm Sect.

UWAGA / NOTE

Kod dla wersji 42CrMo4 zawiera literę "H" (np. BE P12R5H).

The code for the version 42CrMo4 contains an "H" (ex: BE P12R5H).

kN/m 4000	Mt ■ ■	KOD	R
---------------------	---	------------	----------

Dostępne długości
Lengths available

515 mm
550 mm Sect.
1000 mm Sect.

UWAGA / NOTE

Kod dla wersji 42CrMo4 zawiera literę "H" (np. BE P12R25H).

The code for the version 42CrMo4 contains an "H" (ex: BE P12R25H).



BE P10RFA / P10RFA250

kN/m	Mt	KOD	H
1600	■	BE P10RFA BE P10RFA250	150 250

Dostępne długości
Lengths available
515 mm
1030 mm

BE P12RFA

kN/m	Mt	H
1600	■	130

Dostępne długości
Lengths available
515 mm
550 mm Sect.
1000 mm Sect.

Rounds for BE P10R

kN/m	Mt	KOD	Φ
1600	■ ■	BE PBD28 BE PBD30 BE PBD35 BE PBD40 BE PBD45 BE PBD50 BE PBD55 BE PBD60 BE PBD65 BE PBD70 BE PBD80	28 30 35 40 45 50 55 60 65 70 80

Dostępne długości
Lengths available
515 mm
1030 mm

UWAGA / NOTE
Kod dla wersji 42CrMo4 zawiera literę "H" (np. BE PBD28H).
The code for the version 42CrMo4 contains an "H" (ex: BE PBD28H).

Rounds for BE P12R

kN/m	Mt	KOD	R
4000	■ ■	BE P12R5 BE P12R6 BE P12R8 BE P12R10 BE P12R12 BE P12R15 BE P12R20	5 6 8 10 12 15 20

Dostępne długości
Lengths available
515 mm
550 mm Sect.
1000 mm Sect.

KOD	R
BE P12R5	5
BE P12R6	6
BE P12R8	8
BE P12R10	10
BE P12R12	12
BE P12R15	15
BE P12R20	20

UWAGA / NOTE
Kod dla wersji 42CrMo4 zawiera literę "H" (np. BE P12R5H).
The code for the version 42CrMo4 contains an "H" (ex: BE P12R5H).

Dostępne długości
Lengths available
515 mm
550 mm Sect.
1000 mm Sect.

KOD	R
BE P12R25	25
BE P12R30	30
BE P12R35	35

UWAGA / NOTE
Kod dla wersji 42CrMo4 zawiera literę "H" (np. BE P12R25H).
The code for the version 42CrMo4 contains an "H" (ex: BE P12R25H).



BE P30

kN/m 2000 Mt

KOD	H1	H2
BE P30RFA	125	184
BE P30RFA250	250	309

Also available whit "R" clamp

KOD	H1	H2
BE P30R	100	139

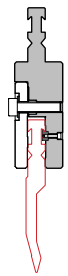

PRZEDŁUŻENIE
EXTENSION

Długość
Length
150 mm

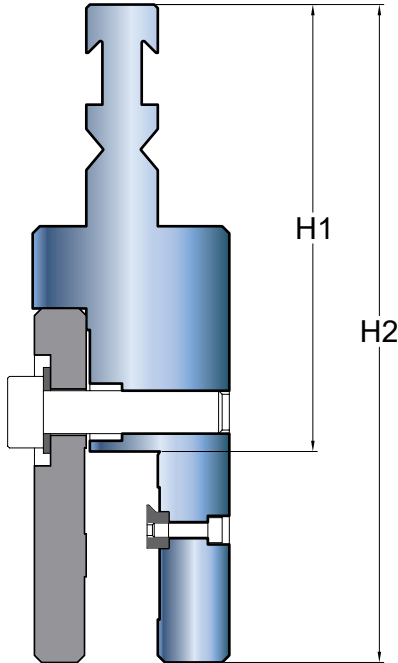

BE P25

kN/m 2000 Mt

KOD	H
BE P25RFA	130
BE P25RFA250	250

Also available whit "R" clamp

KOD	H
BE P25R	105

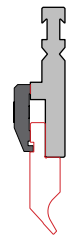

Adapter **BYSTRONIC** - AMADA
Adapter **BYSTRONIC** - AMADA

Długość
Length
150 mm

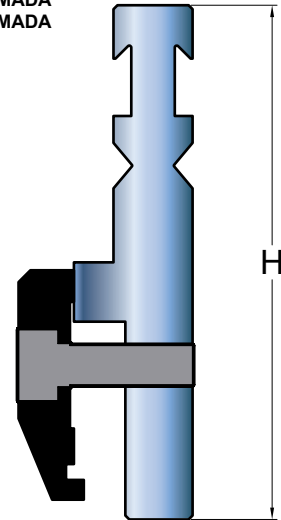

kN/m 2000 Mt

KOD	H
BE S245	45
BE S273	73
BE S2100	100

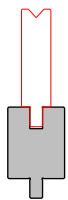

UCHWYT MATRYCY
DIE HOLDER

Długość
Length
515 mm
550 mm Sect. FSW
1000 mm Sect. FSC
1030 mm

Length ref.
Pag. 81

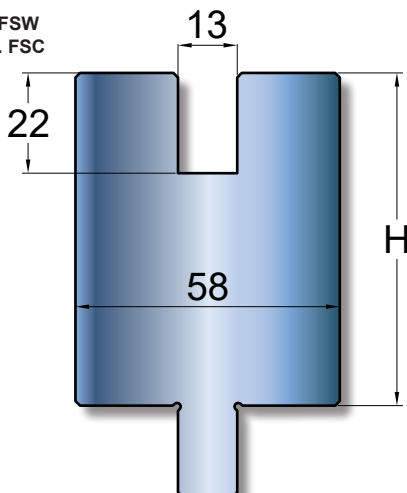



BE Z101R

kN/m	Mt	H1	H2
1000	■	101.0	64.0

Dostępne długości
Lengths available

415 mm
835 mm

BE Z121RFA

kN/m	Mt	H1	H2
1000	■	121.0	64.0

Dostępne długości
Lengths available

415 mm
835 mm



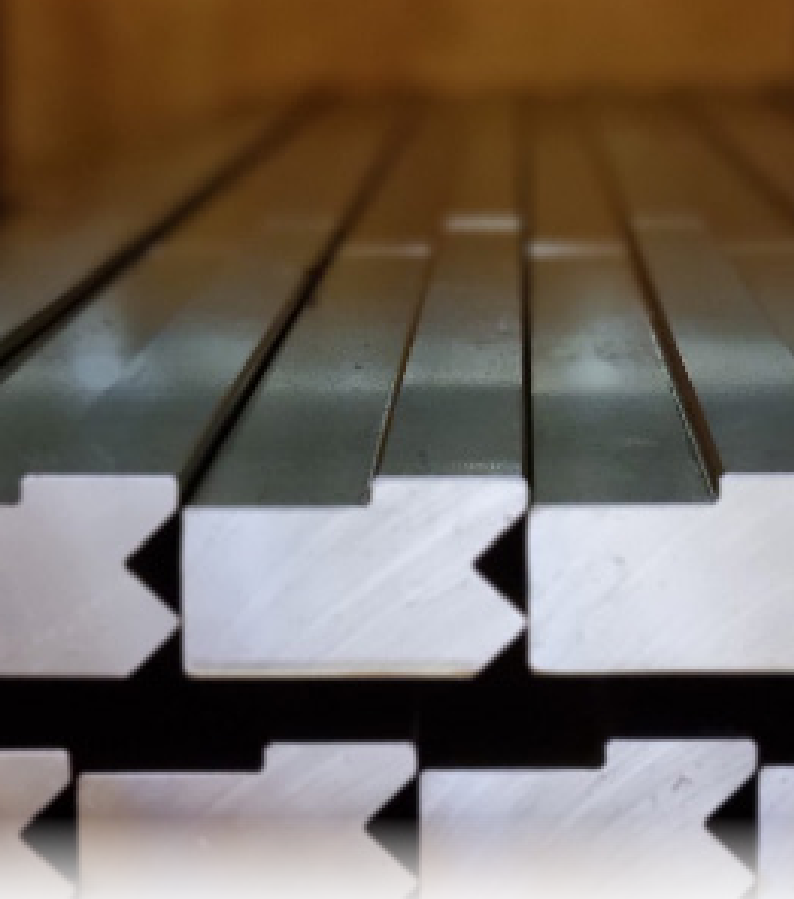

Inserts for BE Z101R - BE Z121RFA

kN/m	Mt	KOD
1000	■	AM 4500

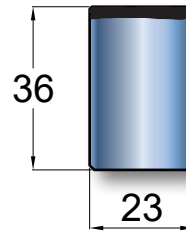

Dostępne długości
Lengths available

415 mm
835 mm

kN/m	Mt	KOD	Z	α	R	T
1000	■	AM 4510	1.0	160°	0.5	1.0
		AM 4515	1.5	160°	0.5	1.2
		AM 4520	2.0	150°	0.5	1.5
		AM 4525	2.5	140°	0.5	1.5

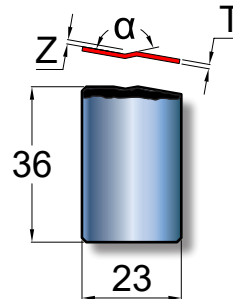

Inserts for BE Z101R - BE Z121RFA

kN/m	Mt	KOD	Z	α	R	T
1000	■	AM 4585	8.5	90°	0.8	2.0
		AM 4590	9.0	90°	0.8	2.0
		AM 4610	10.0	90°	0.8	2.0
		AM 4611	11.0	90°	1.0	2.0
		AM 4612	12.0	90°	1.0	2.0

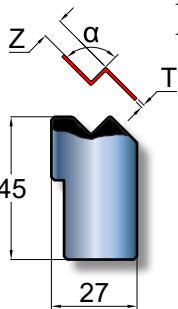

Dostępne długości
Lengths available

415 mm
835 mm

T = Max Grubość
T = Max Thickness

kN/m	Mt	KOD	Z	α	R	T
1000	■	AM 4613	13.0	90°	1.0	2.5
		AM 4614	14.0	90°	1.0	2.5
		AM 4615	15.0	90°	1.0	3.0

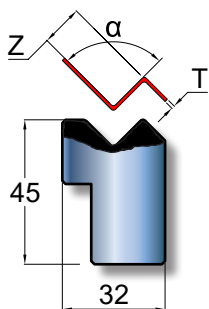

Dostępne długości
Lengths available

415 mm
835 mm

T = Max Grubość
T = Max Thickness

Inserts for BE Z101R - BE Z121RFA

kN/m	Mt	KOD	Z	α	R	T
1000	■	AM 4511	1.0	90°	0.3	0.5
		AM 4516	1.5	90°	0.3	0.5
		AM 4521	2.0	90°	0.5	0.8
		AM 4526	2.5	90°	0.5	1.0
		AM 4530	3.0	90°	0.5	1.0
		AM 4535	3.5	90°	0.5	1.2
		AM 4540	4.0	90°	0.5	1.2
		AM 4545	4.5	90°	0.5	1.5
		AM 4550	5.0	90°	0.5	1.5
		AM 4555	5.5	90°	0.5	1.5
		AM 4560	6.0	90°	0.5	1.5
		AM 4565	6.5	90°	0.5	1.5
		AM 4570	7.0	90°	0.5	1.5
		AM 4575	7.5	90°	0.5	1.6
		AM 4580	8.0	90°	0.5	1.6

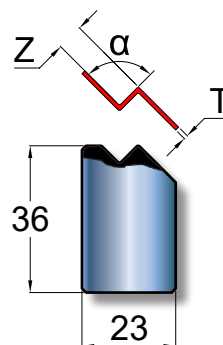

Dostępne długości
Lengths available

415 mm
835 mm

T = Max Grubość
T = Max Thickness



LEGENDA
LEGEND

L=Max Długość stempla
L=Max length tools

N=N° Max pojemność
N=N° Max tools

W= Waga
W= Weight

Inne kolory na zamówienie
Other colours on request



TR 4652

L	N	W
1100 mm	55	450 Kg



TR 4653

L	N	W
1100 mm	30	300 Kg



Szafki na narzędzia są kompatybilne również z liniami:
TRUMPF - LVD - WILA

These tools cabinets are compatible also with lines:
TRUMPF - LVD - WILA

