

asfalg
TOOLS

● LIFTING MAGNETS

● SB200 | SB500 | SB950

● MAGNETIC TOOLS

asfalg
MAGNETS

asfalg
MACHINES

● CLAMPING MAGNETS

Magnesy podnoszące

Bezpieczne podnoszenie i mocowanie

Podnośniki standardowe

Podnośniki wykonane na zamówienie

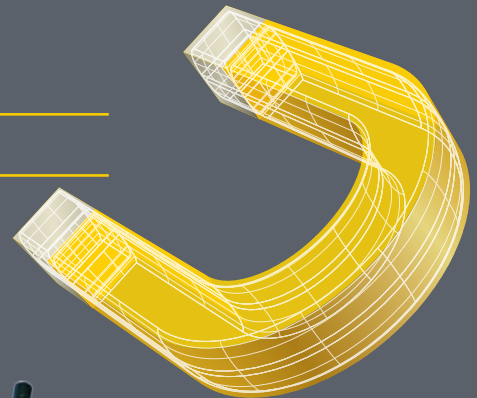

As w dziedzinie metalu

MAGNETS MACHINES TOOLS



Lifting Magnets



Elift
Lifting Magnet

02



EPMH
Electropermanent Lifting Magnet

14



Mlay
Lifting Magnet

04



EPMH
Electropermanent Lifting Magnet

15



**HL | SH 12 |
HL 60-CE |
HL 60-CEL**
Manual Magnet Transporter

06



EPMBL
Battery Magnetic Beam

16



SH 35-K | SH 60-K
Crane Magnet Transporter

07



**Load Lifting Beams
with patented full
steel EPMagnet
Modules**

18



**SB200 | SB500 |
SB950**
Battery Lifting Magnet

08



MAP-MRP Series
Magnetic Gripper
for automation

22



SB950-SF
Battery Lifting Magnet

10



AR Series
Magnetic Gripper
for automation

24



**Positioning drawbar
for Lifting Magnets**

11



AY Series
Magnetic Gripper
for automation

25



EPMB
Battery Lifting Magnet

12



LAY Series
Magnetic Gripper
for automation

26

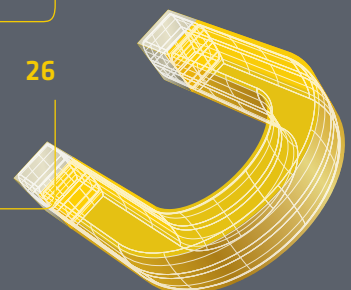

Elift

Lifting Magnet

The unmistakable advantages of the lifting magnets Elift from Assfalg are economy and fast handling.

The hand-operated permanent lifting magnet is the perfect and fully developed solution for moving all ferromagnetic materials in an efficient, safe and reliable way.

- Vertical transport
 $F_v = 1/3 F_h$

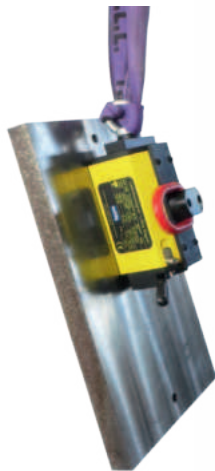

- The safety lock prevents accidental loosening under load

Application

- ▶ For flat and round material, because of v-prism pole shoe
- ▶ Select lifter size according to load and for easy operation of the switching level
- ▶ For raw material, semi-finished and finished products
- ▶ In mechanical engineering, tool manufacturing, plant engineering, steel construction, ship-building, transport company or materials store





- 👉 The “strongest” magnet can lift 5 t of flat material



Professional advantages

- ▶ Absolutely safe lifting – with 3-times safety factor (the pull-off strength is 3 times more as the recommended lifting force)
- ▶ No restrictions on scaled, rough or oily surfaces
- ▶ No damaging of the work piece surface
- ▶ Smooth switching ON/OFF via hand lever
- ▶ Optimization of crane capacity and space because of independent permanent magnet lifter
- ▶ Smooth lever more when switching OFF provided correct lifter size was selected

Features

- 👉 Two-hand operation via hand lever and safety lock
- 👉 Max. operation temperature 80°C
- 👉 Use of durable and extremely strong neodymium magnet materials
- 👉 Compact, sturdy construction, low dead weight

Options

- 👉 Additional crane eye for lifting and vertical transport (load only 1/3, available for Elift 300/Elift 500 (Art. No.47392)
- 👉 Special version for hot temperature use
- 👉 Special version for immersing into profiles or for larger diameters
- 👉 Service and repair according the safety rules

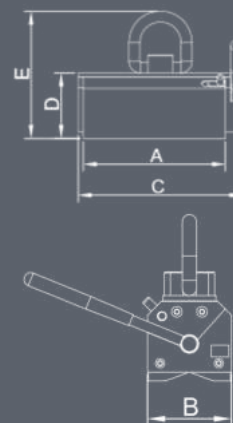

Technical data	Dimensions [mm]					load	Max. load	Load	∅	Max.	Weight	No.
	A	B	C	D	E	SWL 3:1	capacity from	SWL 3:1	from - to	length x width		
						Fh [kg]	[mm]	Fh [kg]	[mm]	[mm]	[kg]	
Elift 100	105	70	133	71	153	100	10	45	40 - 100	1250 × 600	4	50871
Elift 300	181	90	214	87	170	300	15	125	40 - 160	2000 × 1000	10	34858
Elift 500	255	90	288	87	170	500	15	215	60 - 200	2000 × 1500	15	34859
Elift 1000	310	120	335	126	247	1 000	25	450	80 - 350	3000 × 1500	36	34860
Elift 2000	435	176	487	182	331	2 000	30	900	120 - 400	3500 × 2000	110	34862
Elift 3000	530	230	550	186	381	3 000	50	1 350	150 - 400	3500 × 2000	170	43161
Elift 5000	570	370	614	312	552	5 000	60	2 250	200 - 450	5000 × 3000	475	42037

Mlay

Permanent lifting magnets

The manually operated permanent lifting magnets with swiveling single or double hooks are ideal for horizontal and vertical transport of materials.



MLAY 600



MLAY 1000x12

Application

- ▶ For thin and thick sheets depending on magnet size
- ▶ For use on the crane
- ▶ In mechanical engineering, tool manufacturing, plant engineering, steel construction, ship-building, transport company or materials store





MLAY 1000x3



Professional-advantages

- ▶ Absolutely safe lifting – with 3-times safety factor (the pull-off strength is 3 times of the recommended lifting force)
- ▶ The safety lock prevents accidental release under load
- ▶ Smooth switching ON/OFF via hand lever
- ▶ Swiveling single or double hook depending on magnet size

Features

- ✔ Double hook stabilizes the load and reduces dangerous vibrations
- ✔ Single hook for vertical transport
- ✔ Exchangeable pole shoes

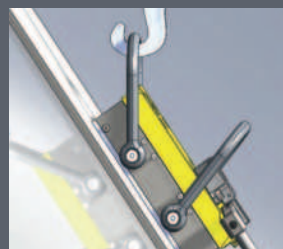

Technical data

	Dimensions [L x W x H]			Load		Min. thickness	Weight	No.
	[mm]			SWL 3:1	[vertical transport]			
				Fh [kg]	Fv [kg]	[mm]	[kg]	
Mlay 600	106	52	184	90	30	12,7	2	63146
Mlay 600x2	221	166	171	166	55	12,7	4,3	64834
Mlay 600x4	236	166	167	346	115	12,7	8,1	63477
Mlay 1000	148	73	254	151	50	19,1	5,2	62315
Mlay 1000x2	251	196	270	302	100	19,1	10,8	62891
Mlay 1000x3	272	196	265	414	138	19,1	16,6	66764
Mlay 1000x4	351	196	251	591	197	19,1	20,5	63980
Mlay 1000x6	511	196	243	977	325	25,4	27,4	66281
Mlay 1000x12	496	307	302	1825	608	31,8	55	63739

HL | SH 12 | HL 60-CE | HL 60-CEL

Permanent Magnet Handlifter

The permanent magnet handlifters SH (from German production) and HL are suitable for transporting especially thin sheets as well as oily or sharp edged ones.

The permanent magnet handlifter HL 60-CE is especially designed for hot or sharp edged flamecut parts. It gets magnetized or demagnetized over push buttons on the handle. The HL 60-CE accu lasts for 1000 switching cycles before recharging. The charger and an exchange accu are included.

The **HL 60-CEL** is with long handle.



SH 12



HL 60-CE



HL 60-CEL

Application

- ▶ Handling of thin sheets or small flamecut parts
- ▶ Max. operation temperature 80°C
- ▶ For HL / SH the workpiece surface should be clean and dustfree (oil does not effect the magnetic force)
- ▶ Usable in mechanical engineering, tool manufacturing, plant engineering, steel construction, shipbuilding, still mill, transport company or materials store

Features HL | SH 12

- Ⓛ Horizontal or vertical sheet transport
- Ⓛ Destacking of even 2 mm sheet thickness
- Ⓛ Very flat magnetic field, especially designed for thin sheets
- Ⓛ Mechanical release by pushing the handle

Delivery contents HL 60-CE | HL 60-CEL

- Ⓛ HL 60-CE | HL 60-CEL
- Ⓛ Charger 230V with 2 x accu 12V

Features HL 60-CE | HL 60-CEL

- Ⓛ Fast handling of sharp-edged or hot metal parts
- Ⓛ Magnetizing or demagnetizing by push buttons
- Ⓛ Nearby no residual magnetism, therefore insensitive to dust or chips
- Ⓛ The electrical switching protects the workpiece surface
- Ⓛ Long lasting exchange accu, up to 1000 ON/OFF cycles

Technical data

	Hold surface	Lifting force	Drag force	Sheet thickness	Weight	No.
	[mm]	Fh [kg]	Fv [kg]	[mm]	[kg]	
HL 10	150 x 100	60	20	> 2,0	2,0	104
HL 20	190 x 140	120	40	> 2,0	3,5	25031
SH 12	133 x 106	120	60	> 2,0	1,3	101
HL 60-CE	56 x 42	27	-	> 5,0	1,1	60347
HL 60-CEL	56 x 42	27	-	> 5,0	2,5	69924

SH 35-K | SH 60-K

Crane Magnet Transporter

Since decades crane transporters of the SH series have been considered to be a economic solution for horizontal or vertical transport by crane. Contrary to other permanent magnet lifters the SH types have a flatter magnetic field especially designed for picking up sheets with 3 mm thickness and more. They are a real alternative to mechanical transport clamps, even for support during sheet bending process.



Vertical transport
 $F_v = 1/3 F_h$



SH 35-K

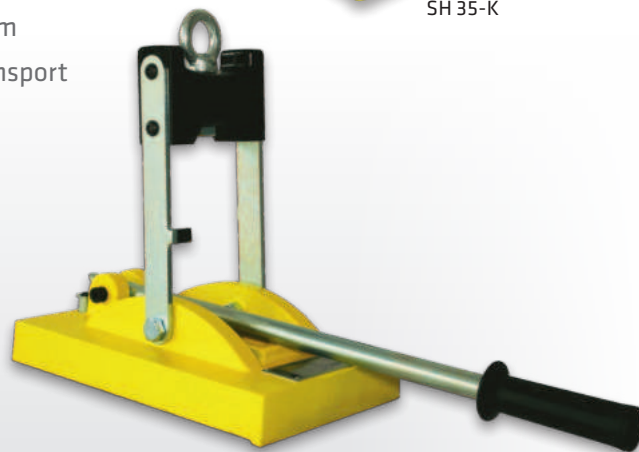

SH 60-K

Application

- ▶ Suitable for sheets with thickness from 3 mm
- ▶ Use on clean sheets (oil does not negatively effect magnetism)
- ▶ Sheet or plate can be tilted
- ▶ Usable in mechanical engineering, tool manufacturing, plant engineering, steel construction, shipbuilding, steel mill, transport company or materials store

Features

- ⚙ Mechanical release by handle
- ⚙ Max. operation temperature 80°C

Options

- ⚙ Rope loop for a soft mounting on the crane hook
- ⚙ Service and repair according to safety regulations

Technical data

	Hold surface [mm]	Lifting force SWL 3:1	Drag force SWL 3:1	Sheet thickness [mm]	Weight [kg]	No,
		Fh [kg]	Fv [mm]			
SH 35-K	190 x 110	250	84	ab 3,0	4	105
SH 60-K	310 x 190	500	167	ab 6,0	12	106

SB200 | SB500 | SB950

Battery Lifting Magnet

The electropermanent battery lifting magnets are suitable for the flat material load range of 200kg | 500kg | 950kg and the round material load range of 50kg | 200kg | 400kg. Using a current pulse of less than one second the electropermanent battery lifters SB200 | SB500 | SB950 from Assfalg are switched manually by pushbuttons or automatically. Although no current flows during the transport of the load, the workpiece remains safely clamped like a permanent magnet. Up to 1000 ON/OFF switching cycles by SB200 | SB500 and 500 ON/OFF switching cycles by SB950 are possible before recharging the integrated accu by the supplied mains charger.



SB200

Application

- ▶ For flat and round material
- ▶ Destacking from 4mm sheet thickness by power reduction
- ▶ Independent from mains supply
- ▶ In mechanical engineering, tool manufacturing, plant engineering, steel construction, shipbuilding, steel mill, flame cutting, transport company or materials stores



SB950



SB500



SB500



SB200



SB200 with special pole shoes

Professional advantages

- ▶ No battery flow during lifting (only a current pulse for a few seconds is required for magnetizing or demagnetizing)
- ▶ Replaceable and rechargeable battery box for SB500 and SB950 mounted externally
- ▶ The magnets are either manually switched via push buttons or automatically via AUTO function
- ▶ Power reduction for destacking or low weight loads
- ▶ A built in security mechanism prevents switching when the load is suspended
- ▶ Option: Positioning drawbar SB 950, swivel-mounted in Z-Axis +/- 60°

Features

- ✔ Auto mode is instead of wireless control
- ✔ Up to 1000 ON/OFF switching cycles before recharging
- ✔ Accu (lithium-ion battery) is charged in approx. 2h mains charger 110V / 230V / 50-60Hz

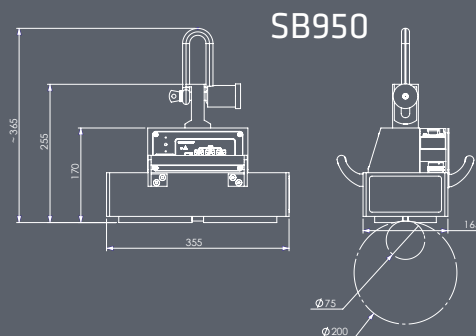
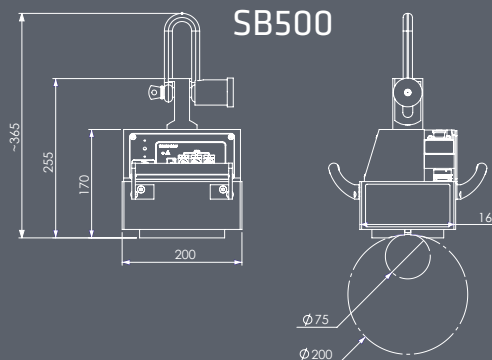
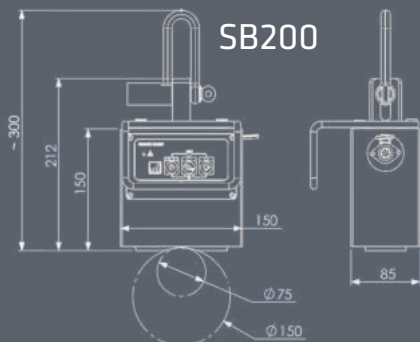

Technical data

	Dimensions [LxWxH]	Load SWL 3:1	Min. thickness	Max. load capacity from	Load SWL 3:1	Ø from - to	Hold surface	Weight	No.
	[mm]	Fh [kg]	[mm]	[mm]	Fh [kg]	[mm]	[mm]	[kg]	
SB200	150 x 85 x 150	200	4	20	50	75 - 150	115 x 50	10	65697
SB500	200 x 160 x 170	500	4	20	200	75 - 200	145 x 125	26	62666
SB950	355 x 165 x 170	950	4	20	400	75 - 200	320 x 130	41	60643

SB950-SF

Battery Lifting Magnet

The electropermanent battery lifting magnet is suitable for the flat material load range of 950kg and the round material load range of 400kg. It has an installed sensor. It measures the magnetic force, compares it with the workpiece weight and shows on the display if the workpiece can be transported. Parameters such as surface property, material thickness and material are considered here.

The automatic mode allows for contactless switching. A switch process is generated each time the magnets are added and the crane eye let relieved and the magnet switches on or off. It is no longer necessary to bend or climb machine tables. Together with the optionally available positioning drawbar, workpieces can be picked up, guided and placed down accurately.



Professional advantages

- ▶ Visual load display
- ▶ No current flows during lifting (only an electrical impulse for a few seconds is required for magnetizing or demagnetizing)
- ▶ The magnets can be switched manually through a push button or automatically through a pick-up mechanism
- ▶ 3 power levels to lift materials with a thickness starting at 4 mm
- ▶ Externally mounted replaceable and rechargeable battery box

Features

- ⚡ Optical and acoustic warnings for battery charge state
- ⚡ Up to 1000 ON/OFF switching cycles before recharging
- ⚡ Accu (lithium-ion battery) is charged in approx. 2h mains charger 110V / 230V / 50-60Hz

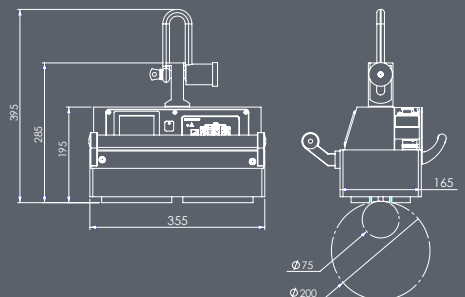

Technical data

	Dimensions	Load	Min.	Max. load	● Load	∅	Hold surface	Weight	No.
	[L×W×H] [mm]	SWL 3:1 Fh [kg]	thickness [mm]	capacity from [mm]	SWL 3:1 Fh [kg]	from - to [mm]	[mm]	[kg]	
SB950-SF	355 x 165 x 195	950	4	20	400	75 - 200	320 x 130	46	68115

Positioning drawbar

For Lifting Magnets

Positioning drawbar for guiding and positioning the SB, EPMB and EPMM lifting magnets. The positioning drawbar has a gradual flexible range of +/- 60°.

The adjustment occurs easily by loosening the hand brake.

A wireless remote control can be installed directly on the handle to switch the magnets on and off. Other remote controls to control cranes are possible on request.



Professional advantages

- ▶ Workpieces can be precisely picked up, guided and set down
- ▶ Optional: radio remote control for switching the magnet

Features

- Ⓛ Made of stainless steel
- Ⓛ Infinitely variable swivel range adjustable +/- 60
- Ⓛ Mounted with 4 screws, can be removed at any time

Technical data

	Dimensions [L]	Weight	No.
	[mm]	[kg]	
Positioning drawbar	1300	9,5	70129

EPMB

Battery Lifting Magnet

The electropermanent battery lifting magnets can be used without connection to the power supply. They combine safety of permanent magnets with the operation comfort of electromagnets. Sheets from 6 mm thickness can also be separately lifted from stack. Even magnetizing and demagnetizing of the lifting magnet can take place automatically.



- 🕒 The automode mechanism: The magnet switches automatically, as soon as it is put on the workpiece and the crane hook is released!

Application

- ▶ For flat and round material because v-prism pole shoe
- ▶ Operation is independent from mains supply
- ▶ Usable even for beam operation with 2 magnets
- ▶ For raw material, semi-finished and finished products
- ▶ In mechanical engineering, tool manufacturing, plant engineering, steel construction, shipbuilding, steel mill, cutting-, laser operation, transport company or materials store



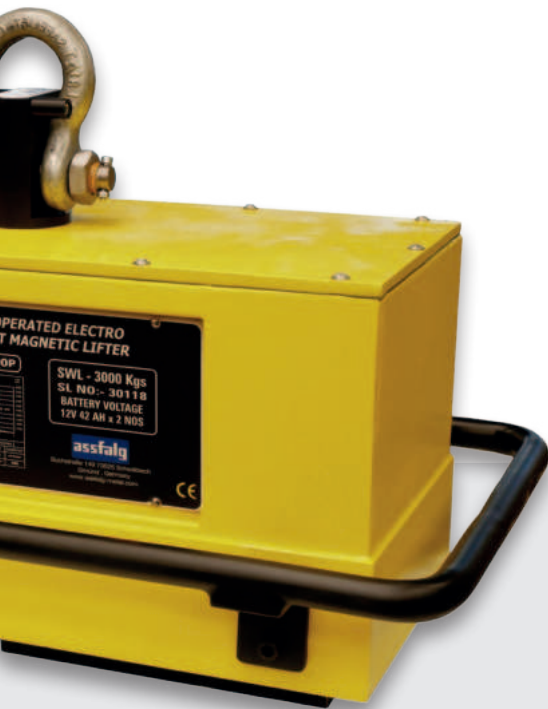

EPMB 5000



EPMB 10000

Professional advantages

- ▶ Automatic magnetizing and demagnetizing of the workpiece by AUTO mode
- ▶ 3 times safety factor and additional safety feature to drop accidentally the load in the air
- ▶ Scaled or rough surface can be mastered
- ▶ No current flow during lifting - the magnet is magnetized or demagnetized by pulse current only
- ▶ Usable in multi-shift operations, because approx. 300 switches are possible

Features

- ⊖ Selection between manual or automatic mode
- ⊖ Max. operation temperature 80°C
- ⊖ Optical and acoustic alarm device with battery charge level indicator
- ⊖ Inching for destacking is possible either by power reduction button or by optional wireless remote control
- ⊖ 300 operation cycles before recharging 8h by mains supply of 110V / 230V

Options

- ⊖ Special pole shoes for round material
- ⊖ Radio remote control for destacking sheets from 6 mm thickness or for dropping during lifting or for use with spreader beam
- ⊖ Service and repair according safety regulations

Technical data

	Dimensions	Load	Min. thickness	Max. load	Load	Max. ø	Hold	Weight	No.
	[L×W×H]	SWL 3:1	for separating	capacity from	SWL 3:1		surface [L×B]		
	[mm]	Fh [kg]	[mm]	[mm]	Fh [kg]	[mm]	[mm]	[kg]	
EPMB 3000	560 x 340 x 500	3 000	6	40	1 500	300	460 x 230	190	28527
EPMB 5000	740 x 410 x 320	5 000	6	50	2 500	300	680 x 380	520	33855
EPMB 10000	1 060 x 500 x 600	10 000	6	70	-	-	1 060 x 500	715	64358
EPMB 3000L	940 x 220 x 280	3 000	6	40	-	-	880 x 180	190	60429
EPMB 5000L	1 250 x 290 x 340	5 000	6	40	-	-	1 150 x 220	250	64294

EPMM

Electropermanent Lifting Magnet

This EPMM magnets are used for frequent handling of workpieces when mains supply is available.

The switching time is rather short.

They combine the safety of permanent magnets with the convenience of electromagnets.

Only short pulse current is needed for switching, hence energy consumption is very low.

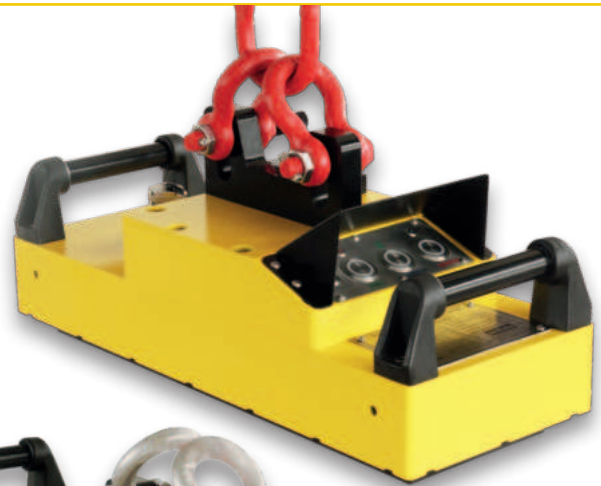

EPMM 2500



EPMM 4000

Professional advantages

- ▶ Very short switching cycles
- ▶ No drop of workpiece when power supply fails
- ▶ Mainly maintenance free
- ▶ Reduction of power for destacking from 6mm sheet thickness

Features

- ⊕ Integrated controller for 400V / 50-60Hz / 16-63A mains supply
- ⊕ Max. operation temperature 80°C
- ⊕ Selection of manual mode or automatic mode
- ⊕ Option:
 - radio remote control for destacking
 - customized applications

EPMM 2500

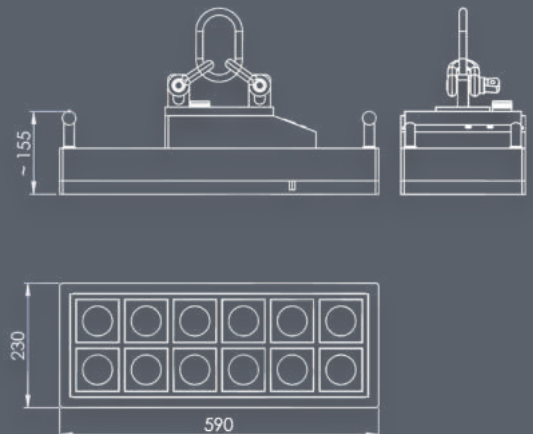

Technical data

	Dimensions [L×W×H]	Load SWL 3:1	Min. thickness	Max. load capacity from	Hold surface	Weight	No.
	[mm]	Fh [kg]	[mm]	[mm]	[mm]	[kg]	
EPMM 200	150 x 85 x 150	200	4	20	115 x 50	9	70542
EPMM 500	180 x 160 x 140	500	4	20	160 x 130	25	69840
EPMM 1000	355 x 165 x 170	1 000	4	20	310 x 120	50	69858
EPMM 2500	590 x 230 x 155	2 500	6	15	590 x 230	92	69758
EPMM 4000	860 x 230 x 165	4 000	6	15	860 x 230	140	59785
EPMM 5000	1 000 x 280 x 165	5 000	6	15	1 000 x 280	200	69841

EPMH

Electropermanent Lifting Magnet

EPMH is for lifting and transporting heavy ferrite blocks or slaps, even with rough surface.

The casing is sturdy and equipped with alarm lamp and sound.

The square pole technology guarantees a bigger force concentration in the workpiece and bridges airgaps.



Professional advantages

- ▶ Unsensitve to rusty or rough workpiece surface
- ▶ Low energy consumption because of pulse current for switching
- ▶ No drop of workpiece, when power supply fails

Features

- ⚙️ Integrated controller for power supply 400V / 50-60Hz / 32A
- ⚙️ With tower lamp for indicating ON or OFF
- ⚙️ With buzzer for picking up mode
- ⚙️ Max. load dimension 6 m x 2 m
- ⚙️ Option:
 - radio remote control
 - customized application

Technical data

	Dimensions	Load	Max. load	Weight	No.
	[L×W×H]	SWL 3:1	capacity from		
	[mm]	Fh [kg]	[mm]	[kg]	
EPMH 10	880 x 531	10 000	30	950	63501
EPMH 15	860 x 563	15 000	40	1300	72048
EPMH 20	980 x 577	20 000	40	1750	64582
EPMH 25	1 100 x 637	25 000	80	2150	66251
EPMH 30	1 147 x 625	30 000	80	2700	64583

EPMBL

Battery Magnetic Beam

The Assfalg Battery Electro-Permanent Lifting Magnetic Beam EPMBL has a compact design. Due to the integrated rechargeable battery box, a power connection is no longer required.

The EPM Battery Magnetic Lifting Beam is operated by remote control. The load lifting beam with a max. load of 1,500 kg is equipped with magnetic modules and can thus safely move sheet metal formats from a minimum length of 500 mm to a maximum length of 4,000 mm.



Professional advantages

- ▶ There is no power connection required anymore
- ▶ Optimal adhesive force for different sheet thicknesses (from 3 mm thickness).
- ▶ With the remote control you can operate the typing function (inching: the separation of the sheets)
- ▶ Magnetic zone selection for different sheet sizes

Features

- ⌚ With 400 switching cycles, the battery shows high efficiency in its performance.



Fields of application

- ⌚ Everywhere different sheet sizes and sheet thicknesses are lifted and transported. For example: For loading and unloading of flame cutting/laser systems

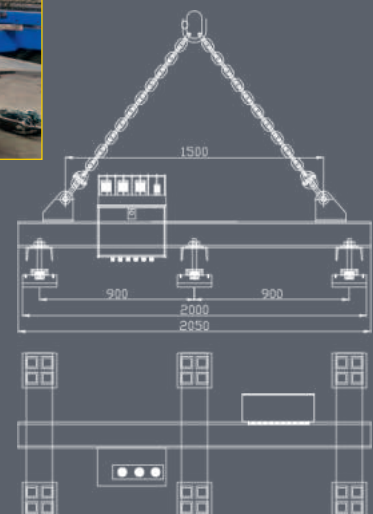

Technical data

	Flatload - SWL 3:1	Min. thickness	Number of modules	Length min. - max.	Width min. - max.	Weight	Item No..
	Fh [kg]	[mm]		[mm]	[mm]	[kg]	
EPMBL	1.500	3	6	500 - 4000	1000 - 2000	700	75016

EPMBL-T

Battery Telescope Magnetic Beam

The Battery Telescopic Magnetic Beam EPMBL-T with automatic telescopic arm is a fully battery operated magnetic lifting beam. It enables the mains-independent lifting and transporting of different sheet metal formats (up to 12 t) from 4 mm thickness.



Professional advantages

- ▶ There is no power connection required anymore
- ▶ Telescopic, reach per side of up to 1000 mm .
- ▶ Optimal adhesive force for different sheet thicknesses (from 4 mm thickness).
- ▶ With the remote control you can operate the typing function (inching: the separation of the sheets)
- ▶ Magnetic zone selection for different sheet sizes
- ▶ ADPREM function prevents random switching in the air

Features

- ✔ With 400 switching cycles, the battery shows high efficiency in its performance.
- ✔ Compact design
- ✔ No damage to the sheets
- ✔ Wood for separating of the sheets are no longer necessary.
- ✔ High flexibility: allows its use on space-saving sheet stacks "fully battery operated" and telescopic.

Fields of application

- ✔ Everywhere different sheet sizes and sheet thicknesses are lifted and transported. For example: For loading and unloading of flame cutting/laser systems

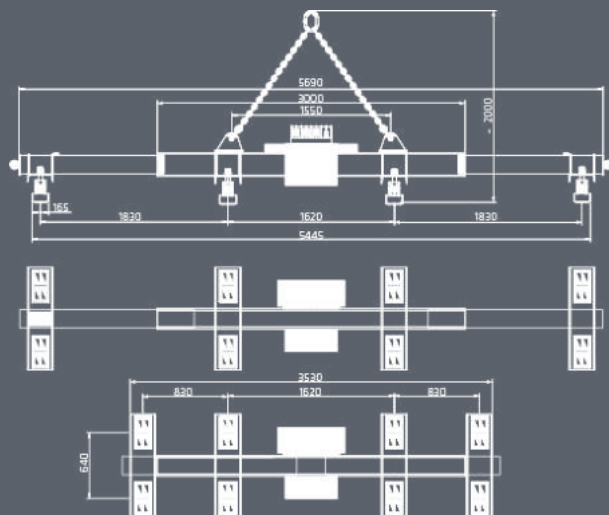

Technical data

	Flatload - SWL 3:1	Min. thickness	Lenght min. - max.	Width min. - max.	Weight	Item No.
	Fh [kg]	[mm]	[mm]	[mm]	[kg]	
EPMBL-T	4.000	4	2.000 - 8.000	500 - 3.000	1.200	74765

Load Lifting Beams with patented full steel EPMagnet Modules

The EPMagnet modules are switched by mains power supply. They combine the safety of permanent magnets with the convenience of electromagnets. Sheets from 5 mm thickness can be destacked.

Magnetizing and demagnetizing of the EPM lifting system can happen manually or by radio remote control. For uneven sheet formats the EPMagnet modules are equipped with spring suspensions.

The EPMagnet modules are integrated in a magnet unit, which is fixed to the beam.



Application

- ▶ Especially for sheet lifting
- ▶ Destacking by remote control
- ▶ For loading or deloading flamecut systems on trucks
- ▶ More flexibility with telescopic beams
- ▶ For feeding and clearing of flame-cutting-/laser systems, also in multi-shift operation
- ▶ Optional: EPMagnet modules for horizontal and vertical transport





Features

- ✔ EPM lifting system is ready for use up to the crane hook
- ✔ Power supply is 400V / 50-60Hz / 16A or 32A
- ✔ Lamp and buzzer indicates the magnetization and demagnetization process
- ✔ Picking up is done with 70% power and automatically increased to 100% after 10 seconds
- ✔ Accidental demagnetization during lifting is prevented by ADPREM safety mechanism
- ✔ Different magnetic zones can be selected according to sheet size
- ✔ Low energy load consumption because of pulse current for switching
- ✔ No drop of load when power supply fails

Options

- ✔ Customized beam and EPMagnet modules
- ✔ Triggering of each EPMagnet module
- ✔ Special safety features for automation
- ✔ Integration of load cells and magnet flow sensors



Overhang table for safe load transport

Thickness of the steel plate (mm)	4	5	7	8	10	12	15	18	20
Max. overhang of the steel plate (mm)	1100	1350	1500	1550	1550	1950	2150	2550	2700

Load Lifting Beams with patented full steel EPMagnet Modules TBK4 | TBK6

The electropermanent telescopic lifting beams TBK4 and TBK6 are designed for lifting and transporting sheets of different sizes from 3m to 16m.

The patented solid steel modules allow destacking from 5mm thickness by radio remote control.

Magnetic zones and power level can be preselected according to sheet size. The EPMagnet modules are equipped with spring suspensions to balance unevenness of sheets.



Application

- ▶ For large sheets
- ▶ Destacking by inching function on remote control
- ▶ Horizontal rotation of EPMagnet units if small long sheets are lifted
- ▶ No drop of sheet when power supply fails
- ▶ Low energy consumption, because of pulse current for switching
- ▶ Customized options



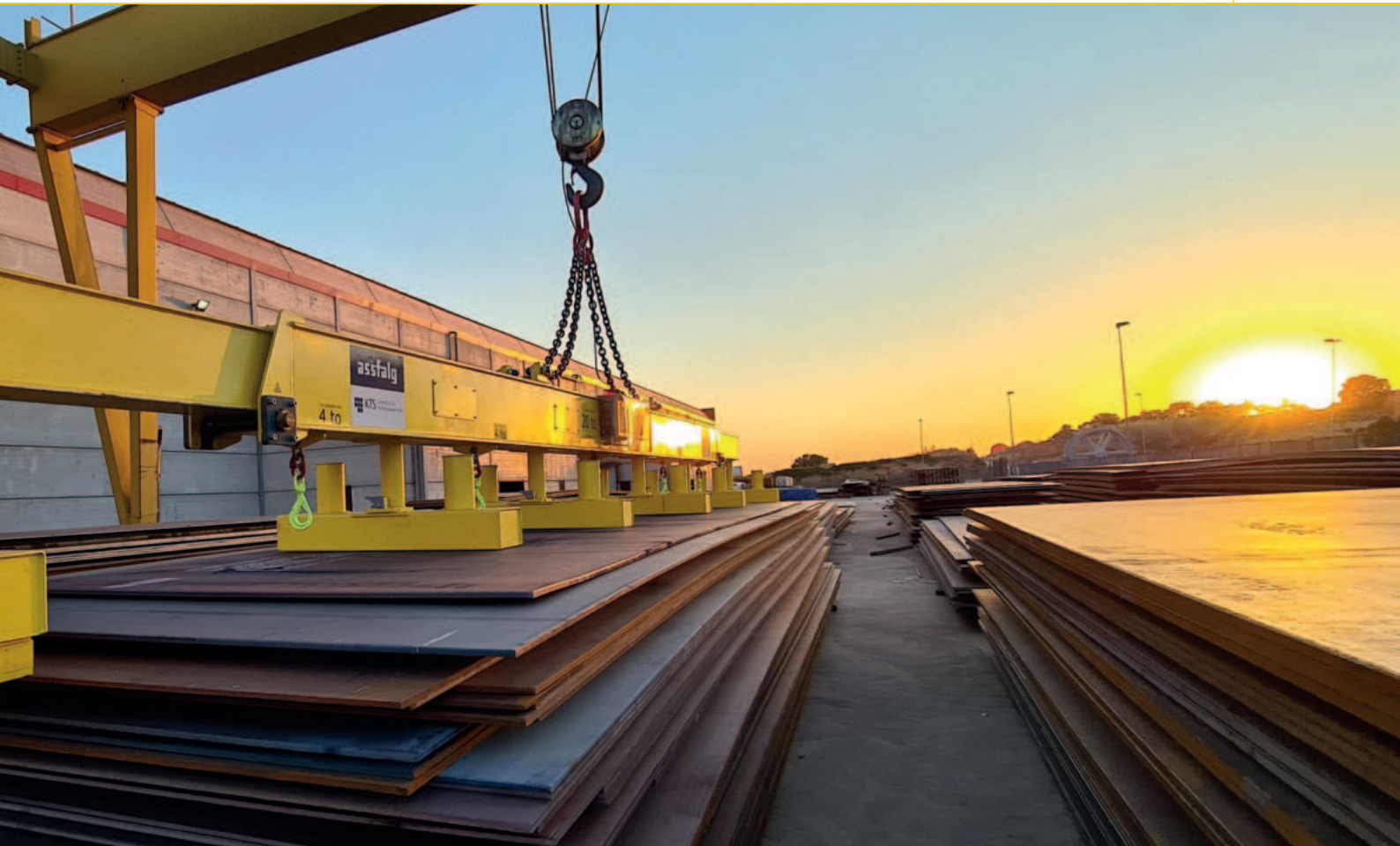

Technical Data TBK4

	Load SWL 3:1	Min. thickness	Length min. - max.	Width min. - max.	Weight	No.
	Fh [kg]	[mm]	[mm]	[mm]	[kg]	
TBK4 / 75	7 500	5	3 000 - 12 000	500 - 2 500	3 000	on request
TBK4 / 100	10 000	5	3 000 - 12 000	500 - 3 000	3 000	on request
TBK4 / 120	12 000	5	3 000 - 12 000	500 - 3 000	3 000	on request
TBK4 / 140	14 000	5	3 000 - 12 000	500 - 3 000	3 000	on request
TBK4 / 180	18 000	5	3 000 - 12 000	500 - 3 000	3 000	on request

Technical Data TBK6

	Load SWL 3:1	Min. thickness	Length min. - max.	Width min. - max.	Weight	No.
	Fh [kg]	[mm]	[mm]	[mm]	[kg]	
TBK6 / 100	10 000	5	2 800 - 16 000	500 - 2 500	4 500	on request
TBK6 / 140	14 000	5	2 800 - 16 000	500 - 3 500	4 500	on request
TBK6 / 180	18 000	5	2 800 - 16 000	500 - 3 500	4 500	on request
TBK6 / 200	20 000	5	2 800 - 16 000	500 - 3 500	4 500	on request
TBK6 / 240	24 000	5	2 800 - 16 000	500 - 3 500	4 500	on request

MAP - MRP Series

Magnetic Gripper for Automation

These permanent magnets cover individual needs and can be fitted for nearly all surfaces.

They get switched within very short cycle time by pneumatic impulse.



MRP-46



MRP 28NK

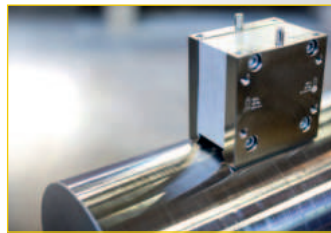

MRP-46

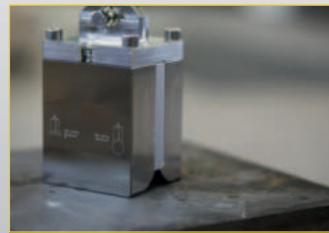

MRP-170

Application

- ▶ For round and flat workpieces
- ▶ For workpieces with irregular surfaces
- ▶ For thin and thick sheets
- ▶ Suitable for automation, lifting operations, robotic technology, welding and clamping technology

Features

- Ⓢ Longlived construction
- Ⓢ Maintenance-free
- Ⓢ Highest safety
- Ⓢ Compressed air demand 5 - 8 bar
- Ⓢ IP Code 67
- Ⓢ Special pole shoes for special surface



MRP-46

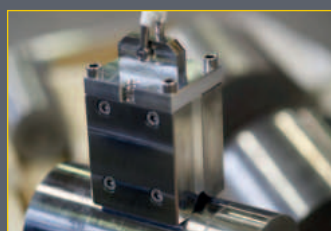

MRP-170

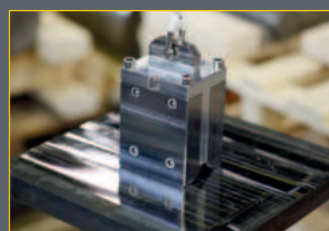

MRP-170



MAP-6

Professional advantages

- ▶ Switchable permanent magnets with 3-times safety
- ▶ Custom-made pole shoes can be fitted to special forms
- ▶ Low residual magnetism
- ▶ Very short switching time by air pressure pulse
- ▶ Low energy consumption



MAP-120R



MAP-120R



MAP-120R

Technical data	Dimensions	■ Load	Min. thick-		● Load	Required	Max. residual gripping	No.
	[\emptyset x H] or [L x W x H]	SWL 3:1	ness	Min. \emptyset	SWL 3:1	diameter	capacity (magnet OFF)	
	[mm]	Fh [kg]	[mm]	[mm]	Fh [kg]	[mm]	[kg]	
MAP-6	\emptyset 35 x 35	6	>4	-	-	-	0,03	63448
MAP-40	\emptyset 65 x 50	40	>8	-	-	-	0,2	63450
MAP-120R	\emptyset 120 x 80	120	>25	\emptyset > 0	70	\emptyset > 200	6	64324
MAP-180	\emptyset 120 x 82	180	>25	-	-	-	6	64333
MRP-28NK	80 x 55 x 126	84	>12	> 12	36	-	0,3	66289
MRP-46	80 x 55 x 82,5	46	>12	\emptyset > 20	30	\emptyset > 120	4	65011
MRP-130F	120 x 103 x 120	130	>25	-	-	-	40	65707
MRP-170	103 x 120 x 140	170	>25	\emptyset > 25	120	\emptyset > 120	30	64823

Gripping capacity vs. material thickness and airgap

	■ Load	Min. thick-	■ Load with thickness of:			■ Load with airgap of:			Weight	No.
			SWL 3:1	ness	2 mm	4 mm	8 mm	0,1 mm		
	Fh [kg]	[mm]	[kg]	[kg]	[kg]	[kg]	[kg]	[kg]	[kg]	
MAP-6	6	>4	12	18	18	8,1	4,5	2,2	0,19	63448
MAP-40	40	>8	22	57	120	79	58	34	0,95	63450
MAP-120R	120	>25	19	60	175	310	270	200	5,80	64324
MAP-180	180	>25	26	80	224	360	270	167	5,80	64333
MRP-28NK	84	>12	28	56	82	126	75	38	2,60	66289
MRP-46	46	>12	36	91	122	100	72	36	1,80	65011
MRP-130F	130	>25	40	119	300	340	300	260	9,50	65707
MRP-170	170	>25	47	147	400	460	410	300	10,7	64823

AR Series

Magnetic Gripper for Automation

The AR permanent magnets are well controlled by air pressure. The rectangular housing is designed for an easy exchange of pole shoes. Special pole shoes are needed for irregular, uneven workpiece forms. The magnets are very flexible because one of 3 possible magnet areas can be used. This magnet is best choice when no flat area exists.

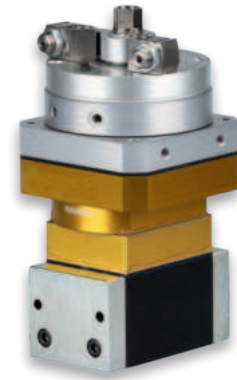
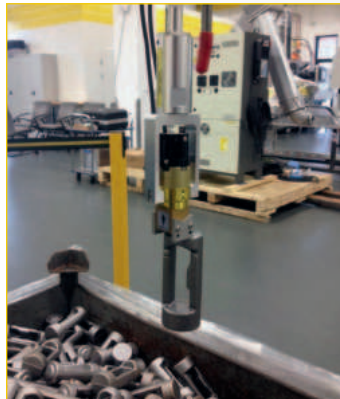

AR 50 Classic



AR 40 Naams

Application

- ▶ For round and flat workpieces
- ▶ For workpieces with irregular surfaces
- ▶ Suitable for automation, lifting operations, robotic technology, welding and clamping technology

Features

- Ⓜ Each AR device is equipped with a set of flat or tube / round pole shoes
- Ⓜ The exchangeable pole shoes can be adapted individually to the workpiece
- Ⓜ Very low residual magnetism
- Ⓜ Universal in application
- Ⓜ Very light and very heavy workpieces can be grabbed

Technical data

	Hold surface [Ø or W x H]	Load SWL 4:1	Min. thickness	Weight	No.
	[mm]	Fh [kg]	[mm]	[kg]	
AR 20	34	7	3	0,4	66675
AR 30	44	15	3,5	0,7	67555
AR 40	55 x 42	43	9,5	1,9	68803
AR 50	64 x 52	62	9,5	2,8	68771
AR 70	92 x 72	110	12,7	6,8	66567
AR 110	150 x 114	356	38,1	28,4	62329

AY Series

Magnetic Gripper for Automation

A highly technical tool series that allows maximum saturation (performance) on thin material. Array units ("AY") offer increased power in a compact, single actuator package. These units are suited to sheet handling on the fly or in shear. This is a revolutionary automation tool that for the first time, truly challenges vacuum suction systems while delivering fast payback on the initial investment. Units can be specified for deep field (JSC) or shallow field (ASC)



M15AY



Application

- ▶ For thin workpieces:
AY-ASC with a flat magnetic field
- ▶ For thick workpieces:
AY-ISC with a deep magnetic field
- ▶ Suitable for automation, lifting operations, robotics technology, welding and clamping technology

Features

- ⊕ Very thin sheets up to 0,5 mm can be separated from the stack
- ⊕ Absolutely safe lifting – namely with 4-times safety (the pull-off strength is 4 times of the recommended lifting force)
- ⊕ Very light and very heavy workpieces can be grabbed
- ⊕ Compact and stable
- ⊕ Very low residual magnetism

Technical data	Dimensions [Ø x H] [mm]	Load	Optimal material thickness [mm]	Weight [kg]	No.
		SWL 4:1 Fh [kg]			
M10AY	66 x 105	6	1,0	0,5	72164
M15AY	79 x 112	18	2,7	0,8	67786
M20AY	98 x 127	43	4,8	1,5	71425
M30AY	135 x 153	59	3,4	2,9	67797

LAY Series

Magnetic Gripper for Automation

The "LAY" signifies Linear Array: designed for applications where stability and power are important. Ideal for long cylinders, tubing and rough surface finishes, the multiple magnetic fields in LAY units ensure strong holding forces also on thin material. Each unit comes with replaceable pole shoes for improved on-site serviceability.



LAY70x3

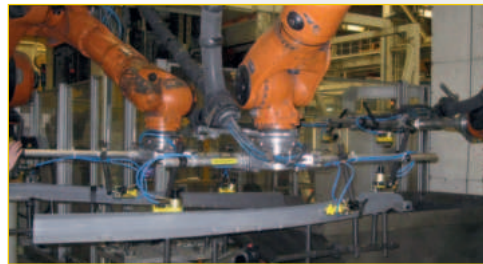
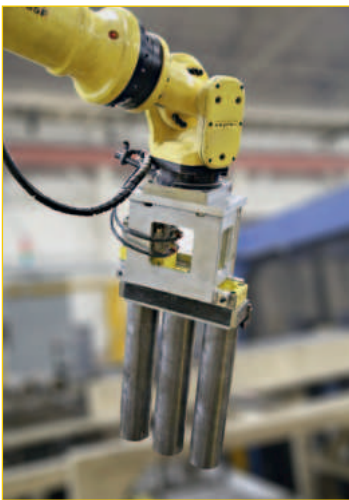

Application

- ▶ Perfect for round and / or flat workpieces
- ▶ Best magnetic forces for thin and thick sheet thicknesses, but also for rough surfaces
- ▶ For workpieces with irregular surfaces
- ▶ Suitable for automations, lifting operations, robotics technology, welding and clamping technology

Features

- ⚙ Exchangeable pole shoes can be used universally
- ⚙ Very strong adhesive forces on rough surfaces (air gap)
- ⚙ Very low residual magnetism
- ⚙ Quick switching by pressured air 6 - 8 bar

Technical data

	Hold surface [L x W] [mm]	Load SWL 4:1 Fh [kg]	Min. thickness [mm]	Load SWL 4:1 Fh [kg]	Weight [kg]	No.
LAY20x4	97 x 32	32	9,5	15	1,2	66532
LAY50x2	119 x 72	125	12,7	50	4,8	66907
LAY50x3	166 x 72	187	12,7	70	8,3	66908
LAY50x4	223 x 72	260	12,7	100	13,6	68293
LAY70x2	177 x 96	240	19,1	90	12,1	67794
LAY70x3	255 x 98	326	19,1	120	16,3	72036
LAY70x4	336 x 98	443	19,1	200	23,2	66898

Assfalg Lifting Magnets in Application

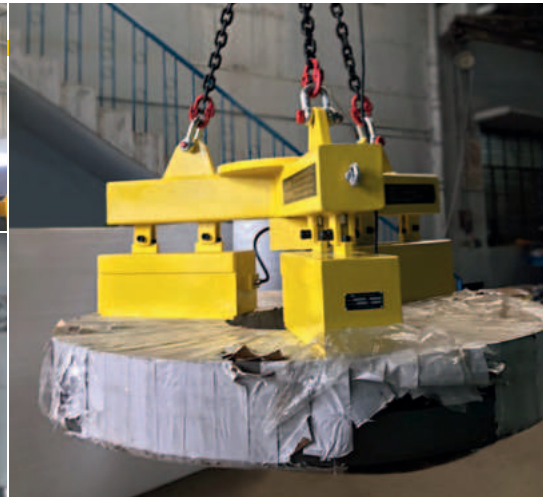
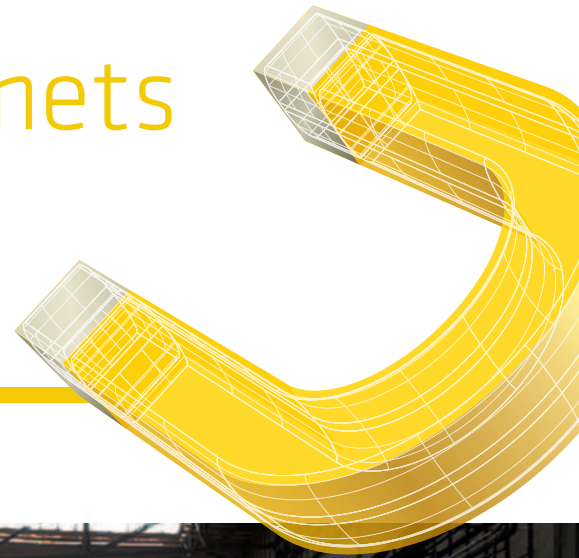

CHCESZ WIEDZIEĆ WIĘCEJ ?

Chętnie doradzimy.

Telefonicznie lub podczas osobistej wizyty.

➔ T +48 884 953 555

➔ T +48 501 669 942

grzegorz.rependa@br-tech.com.pl

piotr.bula@br-tech.com.pl



www.assfalg-metal.com
www.br-tech.com.pl



assfalg

Assfalg GmbH

Buchstraße 149

73525 Schwäbisch Gmünd

Germany